

# The Proven NESTAINER Storage Rack

## Works Wonders with Piece Goods or Boxed Merchandise



### 1. Maximum use of air and floor space.

Nestainers can be positioned in any type of configuration. The base of the Nestainer is raised four inches above floor level so a lift truck can enter from the front or either side.

### 2. Full visual control for most efficient inventory and handling.

### 3. Eliminate individual product rehandling.

### 4. Maximum product protection from production line to warehouse to shipping area to customer.

Each Nestainer unit is constructed of heavy-duty square tubular steel frames welded solidly together. Tough, rugged Nestainers are built to carry any weight requirement up to 4,000 lbs.

### 5. Reconvert storage space back into valuable floor space when the system is not in use.

Twelve units nest quickly and easily to take up no more floor space than one unit alone.

### Nestainers are completely portable, even when nested.

Units can be removed from shipping areas in nested groups, reducing square feet and the number of trips required for removal.

### 6. Eliminate permanent storage racks, wooden skids and expensive hardware.

### 7. Nestainers are well suited to bulk bag storage, shipment, filling and handling applications.

Call  to discuss your application/solutions.

Three bulk bag designs are available.

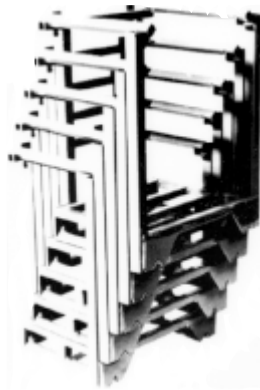

Nested - our exclusive nesting feature which lets you reconvert storage space back into valuable floor space when Nestainers are not in use.

Nestainer construction eliminates costly maintenance problems. All steel one-piece all-welded construction eliminates maintenance of any base pallet, upright locking devices and corner fasteners because Nestainers have no such conventional devices. No wood to break. No bolts to snap. No fasteners to slip. Costs are reasonable, and lead times are short.

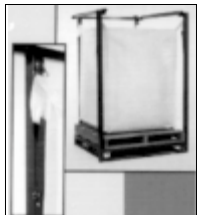

Bulk bag storage and fittings

### How to Specify a Nestainer Rack

In order to supply the Nestainer rack that best fits your specific application, the following information is needed.

1. Brief description of the product to be stored.
2. Pallet/load size - W in. x D in. x H in. (sizing is all clear, outside dimensions).
3. Is there overhang on the pallet?
4. Type of pallet used (2-way or 4-way).
5. Type of rack entry desired (2-way or 4-way).
6. Weight of pallet/load.
7. Stacking height desired.
8. Are there any unusual loading.

Nestainers stack safely and securely in any configuration to maximize air and floor space. The secret to the system and your savings is the patented inverted angle — the bottom angle of the top unit fits perfectly into the top angle of the unit below for the best fixed or portable rack system available.

### CALL FOR A PROMPT QUOTE POPULAR SIZES

Almost any size available

Usable Inside Dimensions W x L x H	Actual Outside Dimensions W x L x H
40 x 48 x 42	44½ x 50 x 50½
40 x 48 x 48	44½ x 50 x 56½
48 x 48 x 42	52½ x 50 x 50½
48 x 48 x 48	52½ x 50 x 56½
53 x 42 x 42	57½ x 44 x 50½
53 x 42 x 48	57½ x 44 x 56½
53 x 48 x 42	57½ x 50 x 50½
53 x 48 x 48	57½ x 50 x 56½
53 x 48 x 54	57½ x 50 x 62½
53 x 48 x 64	57½ x 50 x 72½
53 x 48 x 72	57½ x 50 x 80½
60 x 60 x 42	64½ x 62 x 50½
60 x 60 x 60	64½ x 62 x 68½
60 x 64 x 48	64½ x 66 x 56½
72 x 36 x 36	76½ x 38 x 44½
72 x 48 x 48	76½ x 50 x 56½

Typical Prices  
will vary  
Depending on  
Quantity, Size,  
Capacity, Decks  
and Special  
Features —  
Call For a Quote

### Self-guided Stacking

The Nestainer rack's exclusive inverted angles provide safe, secure and simple stacking.

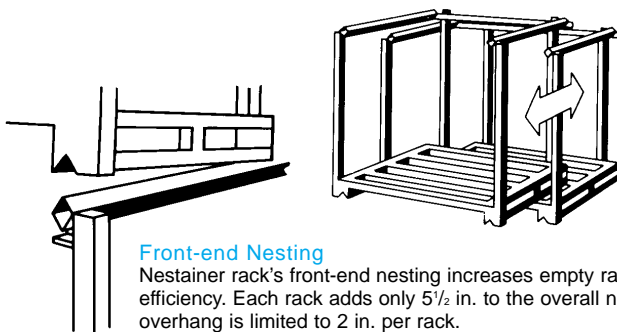

### Front-end Nesting

Nestainer rack's front-end nesting increases empty rack handling and efficiency. Each rack adds only 5½ in. to the overall nested height and overhang is limited to 2 in. per rack.



The one-piece, open construction of each Nestainer facilitates inventory control and maintains lot integrity.

# Portable Pallet Tying Frame Racks

## Steel Piece Goods Pallet Frames Fit Onto YOUR Wooden Pallet

For a prompt, accurate quote please supply this information:

### RACK INFORMATION

1. Size of pallet \_\_\_\_\_ " Wide x \_\_\_\_\_ " Long.
2. Type of Product \_\_\_\_\_
3. Approximate weight per pallet load \_\_\_\_\_
4. Number of loads you will stack \_\_\_\_\_
5. Type of fork truck (counter balanced \_\_\_\_\_ Straddle \_\_\_\_\_)
6. Approximate quantity needed \_\_\_\_\_
7. Thickness \_\_\_\_\_ " height \_\_\_\_\_ " length \_\_\_\_\_ " of stringers on wood pallet
8. Thickness \_\_\_\_\_ " width \_\_\_\_\_ " length \_\_\_\_\_ " of deckboard (top end) on wood pallet.
9. Thickness \_\_\_\_\_ " width \_\_\_\_\_ " length \_\_\_\_\_ " of deckboard (bottom end) of wood pallet.
10. Spacing between top end deckboard and next inner board \_\_\_\_\_ " on wood pallet.
11. Clear height \_\_\_\_\_ " needed from pallet deck to underside of top cross frame.

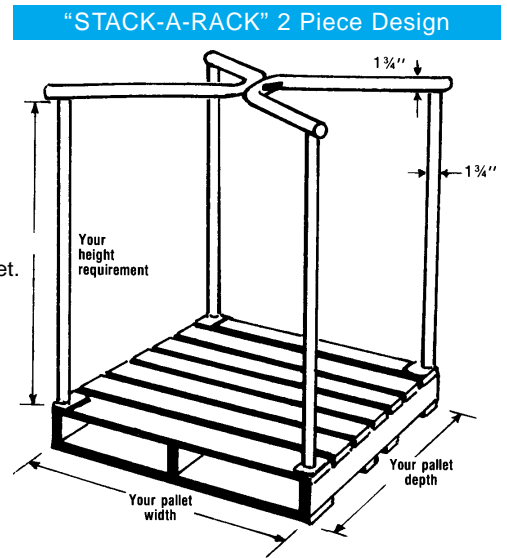
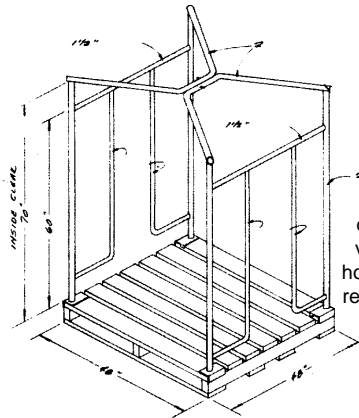
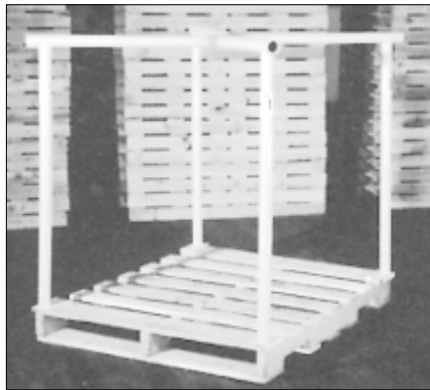

Temporary carton storage placed as needed for access.

The low-cost portable, self-stacking pallet frame for storing piece goods and bulk trim.

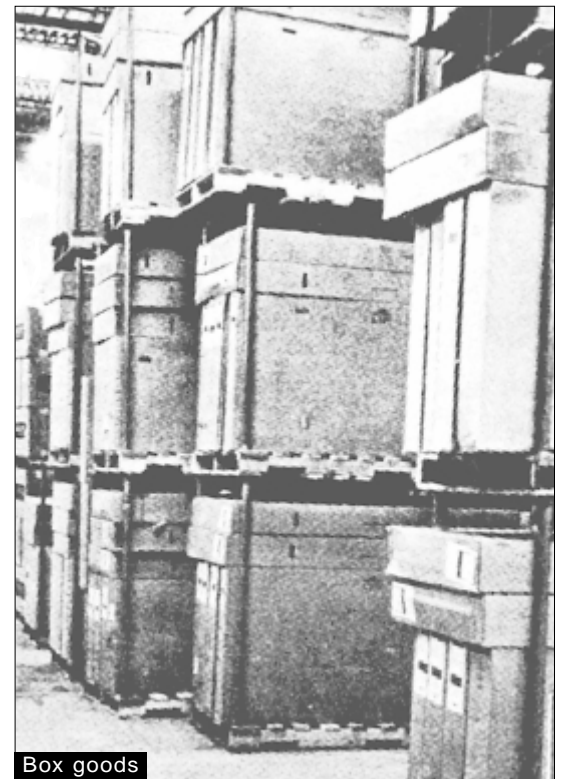
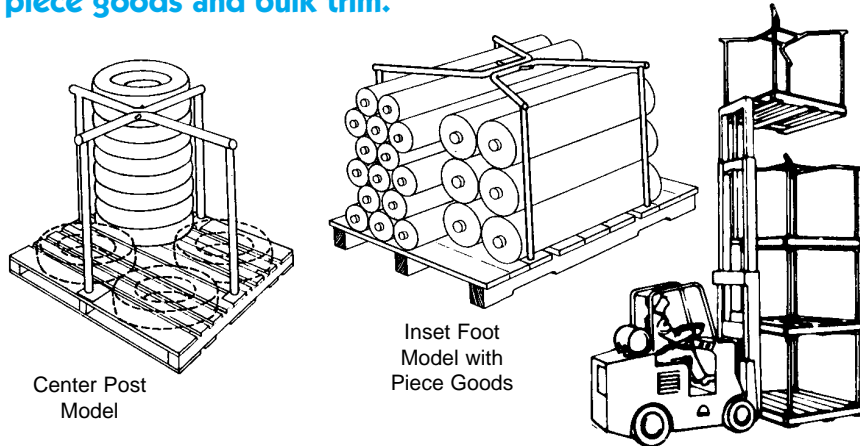

Typical Prices vary depending on quantity, size, capacity, and features.

### EXACT PRICES QUOTED PROMPTLY ON REQUEST

All dimensions are measured in inches — Typical sizes

Posts Clear Height	Pallet Size	Pallet Size	Pallet Size	Pallet Size	Pallet Size
30	—	—	—	—	—
36	—	40 x 30	48 x 30	54 x 30	—
42	36 x 36	40 x 36	48 x 36	54 x 36	60 x 36
48	36 x 42	40 x 42	48 x 42	54 x 42	60 x 42
54	36 x 48	40 x 48	48 x 48	54 x 48	60 x 48
60	36 x 60	40 x 60	48 x 54	54 x 54	60 x 54
66	—	—	48 x 60	54 x 60	60 x 60

For Special Portable Tying Frame Rack requirements, Contact  for quotes.

# TT Tote Boxes and Reusable Shipping Containers

## General Information on TT Injection Molded Container Features Shown on pgs. 83 thru 100

These containers can be used individually or often integrated into a complete system. Our containers have a variety of features and accessories designed to meet your application needs.

### 1. Stacking & Nesting Capabilities

Our containers are designed for secure stacking when full and space-saving nesting when empty.



- Interlocking finger lid design on attached lids allows for secure stacking of loads.
- Bail containers utilize strong metal bails for secure stacking.
- Strong nesting stops ensure space-efficient, jam-free nesting when empty.

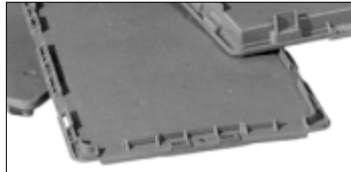

### 2. Types of Lids

Many containers are equipped with either attached or detached lids. Lid styles include recessed, strapping or hi-cube for bulky items.

**Attached lids** feature heavy-duty, molded-in, continuous hinges with ends inset to protect them from handling damage. The patented two-piece lid design features interlocking "fingers" and reinforcing ribs for added strength. Attached lids cannot be misplaced; if damaged, they can be replaced.

**Detached lids** may be completely removed from the container for easy access and compact storage. The reinforced lid helps protect contents from contaminants.

### 3. Card Holders

Card Holders provide a convenient way to identify containers' contents or display other information. **Metal clip, frame-type, self-adhesive, or snap-on** card holders may be specially ordered on selected containers. Hot stamping and other identification methods are available. See following pages.



### 4. Fastening Systems

To ensure security, containers with lids are designed to be sealed with plastic strapping, rivets or security ties. **Plastic strapping** may be applied manually or by automation. **Plastic rivets** are applied with our convenient Hand Plunger. **Plastic security ties** allow for quick sealing by hand. Call Ted Thorsen for details.

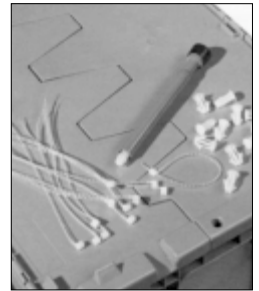

### 5. Open or Solid Bottom

Many containers are available with solid, open, or textured bottoms to meet a wide range of applications. **Solid bottoms** prevent leakage or contamination. **Open bottoms** and **drain holes** allow liquids to be removed from the containers. **Textured bottoms** won't slip on conveyor belts.

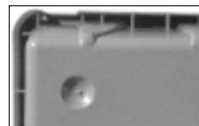
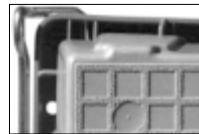

### 6. Handles

Several options are available. **Open handles** offer quick, convenient lifting. **Closed handles** protect contents from foreign materials.

**Ergonomic handles** make lifting loaded containers easy and more comfortable.

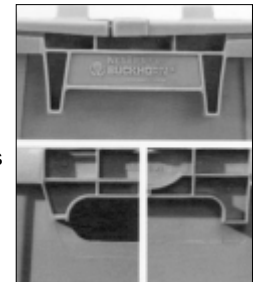

### 7. Colors

Grey is usually the standard color, but often stock is available in red, blue, green, or other colors. Ask about availability. Special colors are always available with minimum quantity runs. Quantities vary by style and size of the container. TT will provide prompt information.

### 8. Sizes

If you don't see the size you need, please call. Often, we can locate the container you need and provide a sample for your test and evaluation.

## TT Plastic Materials Guide

For Catalog #2010

There are many choices in plastic resin materials, which can be very confusing.

TT Ted Thorsen wants to make your decisions easier, so below, we have listed the quality resin materials we use in our products and their attributes. Please refer to this information as you look throughout or catalog for quick material identification.

**Polypropylene:** Rigid and very strong. Highly impact resistant. Hard surface resists scratches. Withstands temperatures between -20 and 130°F.

**Copolymer Polypropylene:** Unique additives increase strength, rigidity, and impact resistance.

**High Density Polyethylene:** Extremely rigid and very strong. Highly impact and chemical resistant. Extremely hard surface is resistant to scratches. Withstands temperatures between -20 and 150°F.

**Co-Polymer Polyethylene:** Unique additives increase impact resistance over standard high-density polyethylene.

**Polystyrene:** More flexible to withstand impacts. Withstands temperatures between -30 and 115°F.

**ABS Materials:** A part of the Styrene family, but superior in UV, impact and weather resistance. High-gloss surface. Withstands temperatures up to 180°F.

**Structural Foam:** Advanced molding process makes an extremely durable product that will withstand heavy loads and high levels of abuse. Withstands temperatures between -30 and 120°F.

**ESD Materials:** Protects sensitive electronic components.

**FDA Approved:** Approved for use in meat and poultry plants.



# "If you're looking to reduce your distribution costs . . . Start by reducing the cost of your container system."

Our Most Competitive Pricing on Top Quality Split Lid Totes

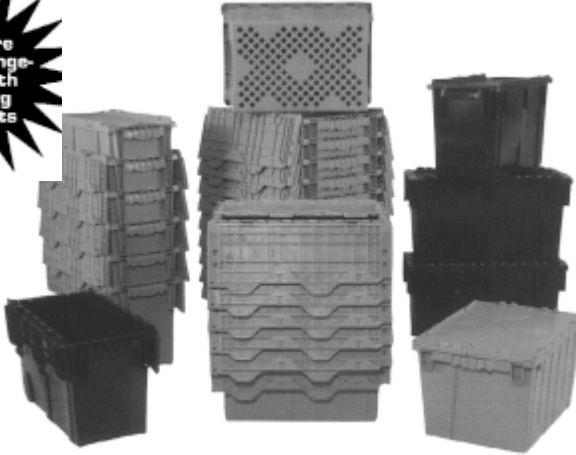

### Features and Benefits:

- Ergonomic carrying handles for easy lifting.
- Solid nesting stops for increased stacking.
- Lid ribbing maximizes load transfer to container.
- Reinforced tie holes minimize lid damage.
- Textured label areas provide easy label removal.
- Traction bottom prevents slipping on conveyors.
- Standard grey color.

### Superior Design and Unsurpassed Quality

The reinforced lids provide exceptional security and the durability needed to ensure years of reliable service. Sturdy nesting stops allow for high stack heights of empty containers. "TRUE FORM" carrying handles (patent pending) follow the shape of your hand and make lifting safer and easier. Large textured surfaces make label removal quick and easy. All DCs feature a traction bottom which is available in a closed, open, or drain hole version.

Backed by a 12 month warranty, the DCs are the best value in the industry.

Model	Outside Dimensions (Metric)				Inside Dimensions (Metric)				Container Height	Product Clearance	Volume (cu. ft)	Weight (lbs)	Nesting Ratio	Price Ea. 1-49 pcs. [CALL]
	Top L	Top W	Bottom L	Bottom W	Top L	Top W	Bottom L	Bottom W						
DC 2115-09	21.90 (556)	15.25 (387)	19.20 (487)	13.25 (336)	20.10 (510)	14.25 (362)	18.90 (480)	13.00 (330)	9.65 (245)	8.50 (216)	1.27 (36 L)	6.10 (2.7 kg)	4:1	[CALL]
DC 2115-12	21.90 (556)	15.25 (387)	18.60 (472)	12.75 (324)	20.10 (510)	14.25 (362)	18.30 (465)	13.00 (330)	12.75 (324)	11.90 (302)	1.67 (47 L)	6.60 (2.9 kg)	4.6:1	[CALL]
DC 2411-14	23.75 (603)	10.90 (277)	21.00 (533)	9.25 (235)	21.80 (554)	10.00 (254)	20.00 (508)	8.25 (210)	14.00 (355)	12.50 (318)	1.25 (35 L)	6.1 (2.7 kg)	3.1:1	[CALL]
DC 2420-12*	23.80 (605)	19.60 (498)	21.25 (540)	17.25 (520)	22.60 (574)	18.50 (470)	21.00 (533)	17.00 (432)	12.50 (318)	11.30 (287)	2.44 (69 L)	8.2 (3.7 kg)	5:1	[CALL]
DC 2717-12	27.30 (693)	16.70 (414)	24.25 (616)	17.70 (450)	25.70 (653)	15.90 (404)	24.00 (610)	14.50 (368)	12.50 (318)	11.30 (287)	2.34 (66 L)	8.70 (3.9 kg)	4.5:1	[CALL]

\*Also available with detached lid. Specifications subject to change without notice.

Discounts:  
50-99 Less 5%  
100-249 Less 7%  
250+ Call

Two New Sizes!  
20"L x 12" W x 7" H [CALL]  
25"L x 15" W x 14" H [CALL]

# "If you're looking to reduce your packaging costs . . . Start by reducing the cost of your package."

## Outstanding Price, Leading Performance

Ted Thorsen's new line of Returnable Stack Only (RSO) containers (left) incorporates our exclusive "DOUBLE WALL" corners for greater strength and durability. "TRUE FORM" carrying handles follow the shape of your hand to make lifting safer and easier. Optional attached lids offer increased product protection, and card holders provide easy identification and improved inventory control. Available in 1/4, 1/6, 1/12 and 1/24 modules. RSO containers are ideal for "just in time" applications.

All Models Available with Attached Lid

Double-Wall Corners Add Strength and Durability

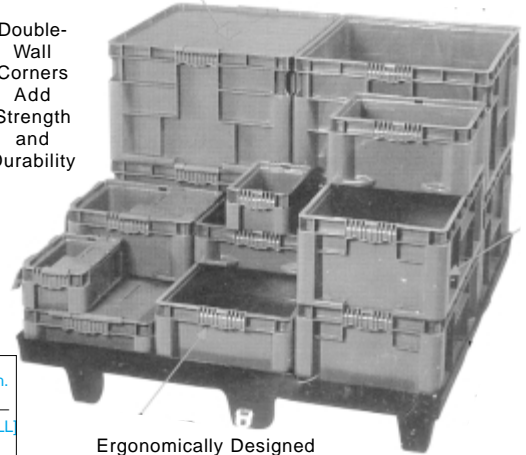

Ergonomically Designed Carrying Handles Make Lifting Safer and Easier.

## Innovation for Warehouse and Transportation Space Saving Applications.

### Specifications: Returnable Stack Only (RSO) Container System

Model RSO Containers	Outside Dimensions (Metric)				Inside Dimensions (Metric)				Container Height	Product Clearance	Volume (cu. ft)	Weight (lbs)	Basic Container Price [CALL]	With Attach. Lid* [CALL]
	Top L	Top W	Bottom L	Bottom W	Top L	Top W	Bottom L	Bottom W						
RSO1207-5	12.0 (304)	7.4 (188)	9.7 (246)	5.8 (146)	9.7 (246)	5.8 (147)	9.4 (239)	5.5 (140)	5.0 (127)	4.3 (109)	0.1 (3 L)	1.4 (0.6 kg)	[CALL]	[CALL]
RSO1215-5	12.0 (304)	15.0 (380)	9.7 (246)	13.3 (337)	9.8 (248)	13.3 (338)	9.4 (239)	13.0 (330)	5.0 (127)	4.3 (109)	0.3 (8 L)	2.0 (0.9 kg)	[CALL]	[CALL]
RSO1215-7	12.0 (304)	15.0 (380)	9.7 (246)	13.3 (337)	9.8 (248)	13.3 (338)	9.4 (239)	13.0 (330)	7.5 (191)	6.8 (173)	0.5 (14 L)	3.0 (1.3 kg)	[CALL]	[CALL]
RSO2415-5	24.0 (608)	15.0 (380)	21.7 (551)	13.3 (337)	21.7 (551)	13.3 (338)	21.4 (544)	13.0 (330)	5.0 (127)	4.3 (109)	0.7 (20 L)	4.0 (1.8 kg)	[CALL]	[CALL]
RSO2415-7	24.0 (608)	15.0 (380)	21.7 (551)	13.3 (337)	21.7 (551)	13.3 (338)	21.4 (544)	13.0 (330)	7.5 (191)	6.8 (173)	1.1 (30 L)	4.5 (2.0 kg)	[CALL]	[CALL]
RSO2415-9	24.0 (608)	15.0 (380)	21.7 (551)	13.3 (337)	21.7 (551)	13.3 (338)	21.4 (544)	13.0 (330)	9.5 (241)	8.8 (224)	1.4 (40 L)	5.2 (2.3 kg)	[CALL]	[CALL]
RSO2422-14 250 pc. min.	24.0 (608)	22.5 (570)	21.7 (551)	20.8 (528)	21.7 (551)	21.0 (533)	21.4 (544)	21.0 (533)	14.5 (368)	13.8 (351)	3.6 (99 L)	8.5 (3.4 kg)	Call	

\*All models available with attached lids. NOTE: Additional discounts over 250 units - Call Ted Thorsen.

Discounts:  
50-99 - 5%  
100 - 249 - 7%  
250+ Call





# Attached & Detached-Lid Containers

**Nest When Empty** • These Containers Last For Years • LOW Prices

Ted Thorsen's Attached and Detached Lid Container System meets retail/wholesale distribution needs from order picking through shipping and storage as well as factory assembly, work-in-process storage, and order picking requirements. Replacing corrugated containers, these versatile containers reduce packaging costs, enhance product protection, and cut product handling time. Four container heights – 5", 7", 9", and 12" – and several styles offer flexibility for your system. Attached lids feature interlocking fingers for tight closure; detached lids snap tight and can be secured with ties or rivets for added protection. Other features include: reinforced sides and corners, open or ergonomic handles, and open or solid bottoms in smooth or textured styles. Optional ID systems include labels and tags.

**These are industrial quality containers — Not retail "specials" for home use!**

## 15" x 14" Attached Lid Containers

- Solid bottom / side design makes this secure for distribution of liquids
- Smooth interior walls are easy to clean
- Model 009-802E will hold 4, 1 gallon jugs or 9, 750 ml. bottles
- Model 009-818E will hold 9, 1.5 or 1.0 liter bottles

Model #	L" mm	W" mm	H" mm	Features	Std. Color	Price/ea. (1-49)
009-802E	14.75 375	13.50 330	13.31 338	EH / SB	Light Gray	<a href="#">[CALL]</a>
009-818E	14.75 375	13.50 343	15.22 387	EH / SB	Special Order	<a href="#">CALL</a>

\*EH = Ergonomic Handles, SB = Solid/Smooth Bottom

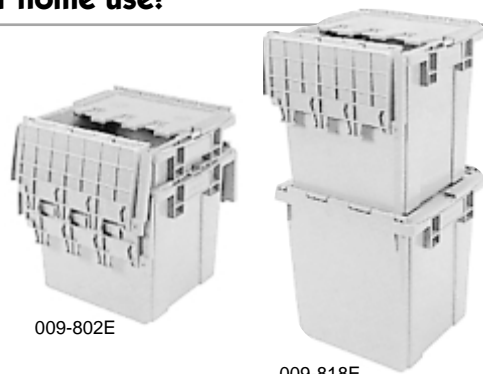

**These tote boxes on these pages are the most widely used returnable plastic shipping containers in the world. Over 12 million have been sold.**

### Features / Benefits:

- Containers stack, nest, and interwork for optimum space utilization on 48" x 40" pallets, in trailers, and in warehouses.
- Detached lids snap tight for secure closure.
- Three lid styles available to fit your needs: Hi-cube, Strapping, Recessed.\*
- Containers and lids have reinforced tie holes in both ends to securely seal containers.

- Textured bottoms available on most models to help prevent slippage on conveyor belts.
- Nesting stops prevent containers from jamming.
- Injection molded HDPE construction resists impact, moisture, and most chemicals.
- See page 83 or call for cardholders and rivets.
- Some optional features require minimum quantity orders. Call for details.

## 20" x 12" Attached Lid Containers

- Unique size maximizes container and trailer cube
- Containers cube 48" x 40" pallets, 8 per layer
- Textured bottom prevents slippage on conveyors

Model #	L" mm	W" mm	H" mm	Features	Std. Color	Price/ea. (1-49)
009-415E	20 508	11.69 297	7.50 191	EH / OTB	Special Order	<a href="#">CALL</a>
009-417E	20 508	11.69 297	7.50 191	EH / STB	Light Gray	<a href="#">[CALL]</a>

\*EH = Ergonomic Handles, STB = Solid/Textured Bottom, OTB = Open/Textured Bottom



## 21" x 15" Container System

- Containers stack, nest, and interwork
- Attached lid containers have ergonomic handles
- Detached lid containers have open and ergonomic handles

### Attached Lid Containers

Model #	L" mm	W" mm	H" mm	Features	Std. Color	Price/ea. (1-49)
009-441E	21.75 552	15.25 387	9.63 245	EH / OTB	Light Gray	<a href="#">CALL</a>
009-443E	21.75 552	15.25 387	9.63 245	EH / STB	Lt. Gray, Red, Green, Blue	<a href="#">[CALL]</a>
009-451E	21.75 552	15.25 387	12.50 318	EH / OTB	Light Gray	<a href="#">CALL</a>
009-453E	21.75 552	15.25 387	12.50 318	EH / STB	Lt. Gray, Red, Green, Blue	<a href="#">[CALL]</a>

### Detached Lid Containers

Model #	L" mm	W" mm	H" mm	Features	Std. Color	Price/ea. (1-49)
009-032E	21.38 543	15.25 387	5.38 137	OH / SB	Light Gray	<a href="#">[CALL]</a>
009-060E	21.38 543	15.25 387	7.88 200	OH / OB	Special Order	<a href="#">CALL</a>
009-062E	21.38 543	15.25 387	7.88 200	OH / SB	Light Gray	<a href="#">[CALL]</a>
009-066E	21.38 543	15.25 387	7.88 200	CH / SB	Special Order	<a href="#">CALL</a>
009-100E	21.38 543	15.25 387	9.56 243	EH / OB	Light Gray	<a href="#">[CALL]</a>
009-121E	21.38 543	15.25 387	9.56 243	EH / OB	Red, Lt. Gray, Lt. Blue	<a href="#">[CALL]</a>
009-173E	21.38 543	15.25 387	12.69 322	EH / STB	Light Gray	<a href="#">[CALL]</a>
010-100E**	21.38 543	15.13 384	1.31 33	LID	Red, Lt. Gray	<a href="#">[CALL]</a>

\*OH = Open Handles, CH = Closed Handles, EH = Ergonomic Handles, STB = Solid/Textured Bottom  
SB = Solid/Smooth Bottom, OB = Open/Smooth Bottom, OTB = Open/Textured Bottom \*\*Detached Lid

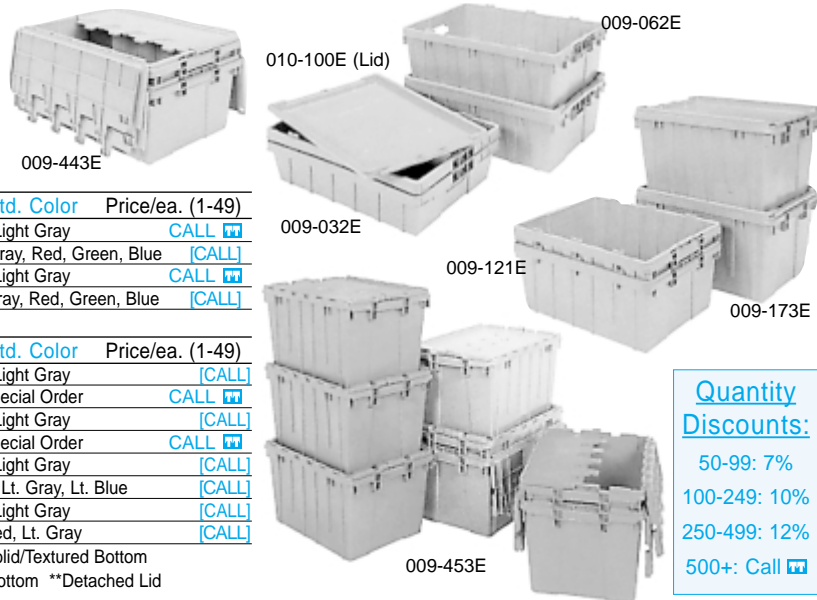

### Quantity Discounts:

- 50-99: 7%
- 100-249: 10%
- 250-499: 12%
- 500+: Call

# The Established Favorites • Pallet Size Matched Container Systems

**Strength and Economy!** - These Attached and Detached Lid Containers will Nest when Empty.

Ted Thorsen distribution containers provide easy handling while maximizing pallet and trailer cube in both stacked and nested positions. A variety of depths provide capacity ranging from .5 to 7.5 cubic feet, and the flexibility to handle products of differing size. Lids are available for rigid stacking; and for use with automatic and manual strapping equipment.

## 22" x 13" & 22" x 16" Attached Lid Container



009-405E

### Bail Containers Available:



009-822E

All Detached Lid containers are available as Bail versions; metal bails flip up for stacking and down for nesting.\*

Contact  for a complete description of these totes.

### 22" x 13" Containers

- Attached lid accommodates strapping to secure container stacks
- Minimal lid flare on nested containers maximizes space usage
- Textured bottoms grip conveyor belts for easy handling

Model No.	L" mm	W" mm	H" mm	Features*	Std. Color	Price/ea. (1-49)
009-403E	22.38 568	13 330	12.88 327	EH/OTB	Special Order	CALL <input checked="" type="checkbox"/>
009-405E	22.38 568	13 330	12.88 327	EH/STB	Light Gray	CALL <input checked="" type="checkbox"/>

\*EH = Ergonomic Handles. STB = Solid/Textured Bottom. OTB = Open/Textured Bottom.

### 22" x 16" Containers

- Used for many distribution applications, including the periodicals industry
- Cube 48" x 45" pallets for optimum space usage

Model No.	L" mm	W" mm	H" mm	Features*	Std. Color	Price/ea. (1-49)
009-000E	17.44 443	14.38 365	2.75 70	RT	Special Order	CALL <input checked="" type="checkbox"/>
009-822E	21.75 552	16.50 419	10.25 260	EH/SB	Slate Blue	CALL <input checked="" type="checkbox"/>
009-826E	21.75 552	16.50 419	10.25 260	SB/SL	Special Order	CALL <input checked="" type="checkbox"/>
009-829E	21.75 552	16.50 419	11 279	SB/SR	Special Order	CALL <input checked="" type="checkbox"/>

\*EH = Ergonomic Handles. SB = Solid/Smooth Bottom. RT = Removable Tray. SL = Slotted Lid. SR = Stacking Rib.

## 22" x 20" Container System

010-200P (Lid)



009-321E

### 22" x 20" Containers

- Containers stack, nest, interwork, and cube 48" x 40" pallets



009-221E



009-593E

### Attached Lid Containers

Model No.	L" mm	W" mm	H" mm	Features*	Std. Color	Price/ea. (1-49)
009-591E	24 610	19.50 495	12.63 321	EH/OB	Special Order	CALL <input checked="" type="checkbox"/>
009-593E	24 610	19.50 495	12.63 321	EH/TB	Light Gray	CALL <input checked="" type="checkbox"/>

### Detached Lid Containers

Model No.	L" mm	W" mm	H" mm	Features*	Std. Color	Price/ea. (1-49)
009-201E	24 610	20 508	10.38 264	OH/OB	Special Order	CALL <input checked="" type="checkbox"/>
009-241E	24 610	20 508	10.38 264	CH/OB	Special Order	CALL <input checked="" type="checkbox"/>
009-301E	24 610	20 508	12.38 314	EH/OB	Special Order	CALL <input checked="" type="checkbox"/>
009-501E	24 610	20 508	12.38 314	EH/OB	Special Order	CALL <input checked="" type="checkbox"/>
009-221E	24 610	19.50 495	10.38 264	OH/STB	Light Gray	CALL <input checked="" type="checkbox"/>
009-321E	24 610	19.50 495	12.38 314	EH/STB	Red, Lt. Gray	CALL <input checked="" type="checkbox"/>

### Lids

Model No.	L" mm	W" mm	H" mm	Features*	Std. Color	Price/ea. (1-49)
010-200P	24 610	20 510	1.13 29	Lid	Gray	CALL <input checked="" type="checkbox"/>
010-201P	24.06 611	20.13 511	1.50 38	Lid	Special Order	CALL <input checked="" type="checkbox"/>

\*OH = Open Handles. EH = Ergonomic Handles. CH = Closed Handles. STB = Solid/Textured Bottom. OB = Open Bottom.

## 27" x 17", 28" x 21", & 34" x 24" Attached Lid Containers

009-571E



009-513E



009-650E



009-521E

### 27" x 17" Containers

- Designed for large, bulky or long parts
- Strapping lid for banding applications (12" height)

Model No.	L" mm	W" mm	H" mm	Features*	Std. Color	Price/ea. (1-49)
009-513E	27.06 687	16.88 429	9.63 245	EH/STB	Special Order	CALL <input checked="" type="checkbox"/>
009-500E	27 686	16.88 429	12.50 318	EH/OTB	Special Order	CALL <input checked="" type="checkbox"/>
009-521E	27 686	16.88 429	12.50 318	EH/STB	Lt. Gray, Red, Green, Blue	CALL <input checked="" type="checkbox"/>
009-523E	27.13 689	16.88 429	12.50 318	EH/STB	Lt. Gray	CALL <input checked="" type="checkbox"/>

\*EH = Ergonomic Handles. STB = Solid/Textured Bottom. OTB = Open/Textured Bottom.

### 28" x 21" & 34" x 24" Containers

- Stacking lugs on lids prevent containers from sliding

Model No.	L" mm	W" mm	H" mm	Features*	Std. Color	Price/ea. (1-49)
009-571E	28 711	20.75 527	15.44 392	EH/STB	Lt. Gray, Lt. Blue	CALL <input checked="" type="checkbox"/>
009-650E	34 864	24 610	19.63 499	OH/SB	Light Gray	CALL <input checked="" type="checkbox"/>

\*OH = Open Handles. EH = Ergonomic Handles. SB = Solid/Smooth Bottom. STB = Solid/Textured Bottom.

QUANTITY DISCOUNTS: 50-99: 7% • 100-249: 10% • 250-499: 12% • 500+: CALL

# 21" X 15" BinBox™ & Bi-Fold Lid Containers

## Eliminate Multiple Handling • Simplify Parts Transfers and Picking

Ship products from a supplier inbound to a distribution center or prepare for order picking, kitting, or assembly – without repacking.

### BinBox Container

#### Unique Cost Saving Design

- Designed for shipping and picking in distribution and manufacturing operations
- Attached lid opens fully for loading; half lid opens back for top access
- Hinged front gate drops down for easy picking
- Interstack with our 21" x 15" System; separate nesting required
- Compatible with most shelving and flow racks

### The BinBox Lid System:

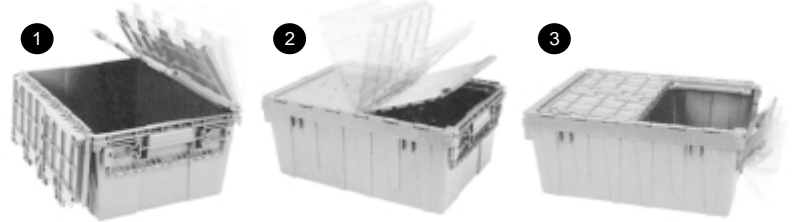

Model No.	L" mm	W" mm	H" mm	Features*	Std. Color	Price/ea. (1-49)
222-223E	21.75 552	15.25 387	9.25 235	EH/SB	Light Gray	[CALL]

\*EH = Ergonomic Handles. SB = Solid/Smooth Bottom.

### Bi-Fold Lid Container

#### For Dense Small Loads

- Bi-Fold lid flaps fold back and lock against nested containers to maximize space usage
- This container does not have an open front.

Model No.	L" mm	W" mm	H" mm	Features*	Std. Color	Price/ea. (1-49)
009-433E	21.50 546	15.25 387	6.63 168	EH/SB	Light Gray	[CALL]

\*EH = Ergonomic Handles. SB = Solid Bottom.

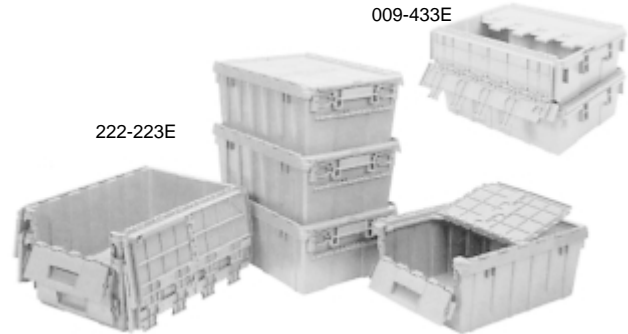

QUANTITY DISCOUNTS: 50-99: 7% • 100-249: 10% • 250-499: 12% • 500+: CALL [CALL]

## A.L.C.'s Attached Lid Containers • Reusable Shipping, Distribution, and Storage Containers

A.L.C. containers are injection molded from high density polyethylene for superior strength and durability. The containers are completely modular, and stack one on top of the other to form stable arrangements.

A.L.C.'s were designed with convenience in mind. Lids are attached to the container bodies so they can never be out of reach. They fold out of the way when loading or working out of the box, then snap securely closed.

A.L.C.'s come in three different sizes. Empty boxes nest for compact storage when they are not in use.

Other features include ergonomically designed molded-in handle grips, anti-jamming ribs, padlock eyes for security, and full-length stainless steel hinge pins for durability. Textured bottoms increase container conveyability.

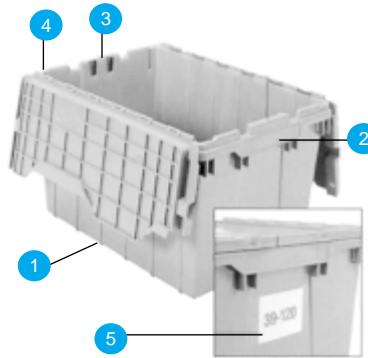

Attached Lids never get lost.

Containers nest when empty to save space.

A.L.C.'s stack for maximum storage.

### Features of Attached Lid Containers

1. Textured bottoms provide a sure grip on conveyor belts.
2. Strong molded-in handle grips are ergonomically designed for easy lifting and carrying.
3. Padlock eye gives a security option.
4. Reinforced hinge pins for years of smooth lid operation.
5. Label holders for quick content identification. Fits all A.L.C.'s. 4 1/2" x 3".

Order information: Color is Gray.

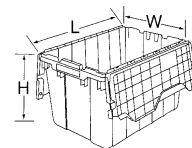

Standard color is Gray.

### Label Holders



Adhesive label holders provide quick content identification. 4 1/2" x 3".

Model No.	Carton Qty.	Price/Pkg.
39010	24	[CALL]

### A.L.C.'s

Model No.	Outside Dimensions						Inside Dimensions Top						Inside Dimensions Bottom						Cu. Capacity	Ctn. Qty.	Price Each
	L	W	H	L	W	H	L	W	H	L	W	H	L	W	H	Ft.	Gal.				
39085	21 1/2	15	9	546	381	229	19 3/4	14 1/2	8 5/8	502	368	219	18 1/16	13 3/4	468	337	1.12	8.5	6	[CALL]	
39120	21 1/2	15	12 1/2	546	381	318	19 3/4	14 1/2	12	502	358	305	18 1/16	13 3/4	468	337	1.62	12	6	[CALL]	
39170	21 1/2	15	17	546	381	432	19 3/4	14 1/2	16 1/8	502	358	429	18 1/16	13 3/4	468	337	2.28	17	3	[CALL]	

Order in carton quantities. • Discount schedule: please see above.

# Modular Handling Systems - 45" x 48" / 30" x 32"

Structural Foam and Injection Molding Plastic Designs • Industrial Standard Footprints

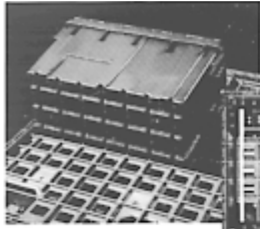

Interlocking rib & channel design. 45" x 48" pallet

45" x 48" Pallet  
472-595E

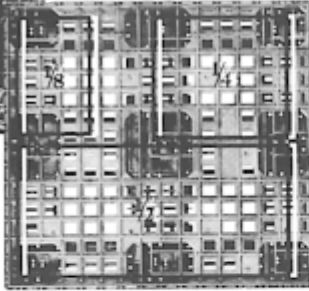

1/4 Size Nested

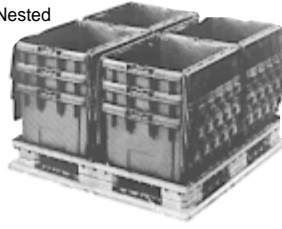

1/6 Size Stacked



1/8 Size Stacked

30" x 32" Pallet  
472-585E

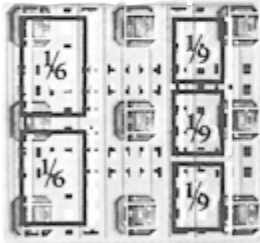

472-566E Lid

1/9 Size Nested



1/9 Container  
472-525E



1/16 Size  
472-516E

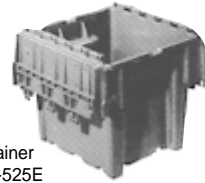

**Optional Cardholder** allows for easy container and contents identification to improve inventory control. Hot stamping, labels, and other identification options available.



1/4 Size - 472-555E



1/4 Long



1/8 Size Tall  
472-545E



1/8 Short  
472-535F



1/6 Container  
472-527E



Model 472-545E in use.

The returnable container system is built to meet the tough demands of Just-In-Time delivery systems.

Four sizes of modular containers nest and lock on a common 45" x 48" pallet. Containers interlock with the pallet's rib and channel design for increased stability.

When the accumulated weight of densely packed, small parts is a major factor in container selection, we

recommend our 30" x 32" modular system.

Two sizes of containers stack, nest and lock on a common 30" x 32" pallet.

Optional card holders can be attached on two sides of the containers for quick content identification. Areas for permanent hot-stamp identification are molded on the sides of containers. Eighth and quarter-size containers

have attached, interlocking lids. Only the half-size model is available with a detached, separate lid.

Pallets are four-way entry for ease of handling and fit compactly in both standard and wide-body trailers to eliminate wasted space. A beveled-entry port model can be moved with a hand jack or fork lift. Pallets and containers are molded plastic and do not absorb oil, corrode or rot.

## SPECIFICATIONS AND PRICING

Model Number	Description	Outside Top Dimensions LxWxH	Inside Top Dimensions LxWxH	Capacity (cu. ft.)	Weight (lbs.)	Nesting Ratio	PRICE 1-24 pcs.
<b>CONTAINER WITH ATTACHED LID - Color: Dark Gray 45" x 48" System</b>							
472-535E	1/16 Size	11 <sup>3</sup> / <sub>16</sub> " x 10 <sup>7</sup> / <sub>16</sub> " x 7 <sup>1</sup> / <sub>16</sub> "	8 <sup>1</sup> / <sub>16</sub> " x 8 <sup>3</sup> / <sub>16</sub> " x 5 <sup>1</sup> / <sub>2</sub> "	0.25	3.04	3.1:1	[CALL]
472-535E	1/8 Size (short)	23 <sup>3</sup> / <sub>2</sub> " x 11" x 9"	20 <sup>1</sup> / <sub>4</sub> " x 8 <sup>1</sup> / <sub>2</sub> " x 7 <sup>1</sup> / <sub>8</sub> "	0.88	6.125	2.8:1	[CALL]
472-545E	1/8 Size (tall)	23 <sup>1</sup> / <sub>2</sub> " x 11" x 14"	20" x 8 <sup>1</sup> / <sub>2</sub> " x 12 <sup>1</sup> / <sub>8</sub> "	1.46	7.625	3.1:1	[CALL]
472-555E	1/4 Size	23 <sup>1</sup> / <sub>2</sub> " x 19" x 14"	20" x 16 <sup>1</sup> / <sub>4</sub> " x 12"	2.68	10.93	3.1:1	[CALL]
472-561E	1/4 Long	47 <sup>7</sup> / <sub>8</sub> " x 11" x 14"	45 <sup>3</sup> / <sub>4</sub> " x 9 <sup>1</sup> / <sub>4</sub> " x 12 <sup>5</sup> / <sub>16</sub> "	2.74	13.78	3.1:1	[CALL]
<b>CONTAINER WITH SEPARATE LID - Color: Dark Gray 45" x 48" System</b>							
472-565E	1/2 Size	47" x 22" x 14"	42 <sup>1</sup> / <sub>2</sub> " x 17 <sup>1</sup> / <sub>2</sub> " x 12 <sup>3</sup> / <sub>8</sub> "	5.82	23.00	3.1:1	CALL [TV]
472-566E	Lid to fit	47" x 22" x 1"	—	—	10.00	—	CALL [TV]
<b>PALLET - Color: Dark Gray 45" x 48" System</b>							
472-585E	Standard Pallet	48 <sup>3</sup> / <sub>16</sub> " x 45 <sup>3</sup> / <sub>16</sub> "	—	—	59.39	—	(Non-Stock)
472-595E	Pallet w/Jack Openings	48 <sup>3</sup> / <sub>16</sub> " x 45 <sup>3</sup> / <sub>16</sub> " x 6 <sup>1</sup> / <sub>4</sub> "	—	—	59.39	—	[CALL]
<b>CONTAINER WITH ATTACHED LID - Color: Dark Gray 30" x 32" System</b>							
472-525E	1/8 Size	9 <sup>3</sup> / <sub>4</sub> " x 8 <sup>3</sup> / <sub>16</sub> " x 9"	6 <sup>13</sup> / <sub>16</sub> " x 6 <sup>3</sup> / <sub>16</sub> " x 7 <sup>1</sup> / <sub>8</sub> "	.19	2.38	2.18:1	[CALL]
472-527E	1/8 Size	15" x 8 <sup>1</sup> / <sub>4</sub> " x 7 <sup>1</sup> / <sub>8</sub> "	12 <sup>1</sup> / <sub>8</sub> " x 6 <sup>1</sup> / <sub>8</sub> " x 6 <sup>1</sup> / <sub>4</sub> "	.37	3.13	2.3:1	[CALL]
<b>PALLET - Color: Dark Gray 30" x 32" System</b>							
472-575E	Pallet	48 <sup>3</sup> / <sub>16</sub> " x 45 <sup>3</sup> / <sub>16</sub> " x 6 <sup>1</sup> / <sub>4</sub> "	—	—	30.00	—	[CALL]

\*Discounts: 25-49 Pieces - Less 5% • 50-99 Pieces - Less 7% • 100-249 Pieces - Less 10% • 250-499 Pieces - Less 15% • \*Except Pallets - Less 10%

# Flipak® Distribution Containers – Industry's Proven Choice



**NEW** Translucent models show interior contents and colors. Model FP141-CL shown. Six other sizes available. Call  for choices and pricing. See below.

Flipak standard color: gray; certain versions and models also have red, dark blue, medium green, and translucent as standard colors.

## Attached Lid Designs



## FEATURES

- Superior economy, lower cost per trip compared with corrugated boxes. Injection molded HDPE material.
- Attached, hinged covers open easily and close with a tight interlocking fit to provide maximum protection and security.
- A broad range of 25 sizes, from 0.30 cubic ft. to 6.0 cubic ft., to meet distribution requirements.
- Pebble grain bottom surface provides extra traction on conveyors. Three bottoms available: solid, PLUS+GRID® and drain hole.
- Containers stack securely and nest securely, when empty for optimum space utilization in trucks, trailers, and storage, and on pallets.
- Special colors, hot stamped letters/logos and sequential numbering available.
- Optional plastic security ties or strapping of covers gives additional security. Request Item #PT6-/1000 pcs. Ties also available in colors. CALL for price.
- Optional identification methods, as well as a full line of accessories, are available for specific applications. Call .



FP40 Flipak® in use in a modern mail order fulfillment center to handle odd shape and oversize products not suitable for standard picking. Samples available to test in your application. Call .

## FLIPAK® PRODUCT SPECIFICATIONS

Model	Outside Dimensions				Inside Dimensions				Total Container Height	Product Clearance	Container		Load Max. (lb.)	Bottom Container Support Wt. (lb.)	Truckload Qty.		Nest Ratio
	Top L	Top W	Bottom L	Bottom W	Top L	Top W	Bottom L	Bottom W			Weight (lb.)	Volume (cu. ft.)			53' Trailer Nested	53' Trailer Nest	
<b>NEW GENERATION FLIPAKS</b>																	
FP102 (P)	20.7	13.6	17.7	11.0	19.0	12.2	17.1	10.8	9.7	8.5	4.6	1.0	7.	250	3,600	4.4:1	
FP142 (M)	21.8	15.2	19.1	13.5	19.9	14.2	18.5	12.9	9.8	8.7	5.9	1.4	70	700	3,600	4.4:1	
FP142 (CLM)	21.8	15.8	19.1	13.5	19.9	14.2	18.5	12.9	9.8	8.7	5.9	1.4	70	700	3,600	4.4:1	
FP182 (M)	21.8	15.2	18.6	12.9	19.8	14.0	18.1	12.3	12.9	11.8	6.5	1.8	70	700	2,800	4.0:1	
FP182 (CLM)	21.8	15.8	18.6	12.9	19.8	14.0	18.1	12.3	12.9	11.8	6.5	1.8	70	700	2,800	4.0:1	
FP242 (M)	26.9	17.1	24.3	14.6	25.3	15.5	23.4	13.9	12.6	11.5	8.2	2.4	70	700	2,200	4.2:1	
FP242 (CLM)	26.9	17.5	24.3	14.6	25.3	15.5	23.4	13.9	12.6	11.5	8.2	2.4	70	700	2,200	4.2:1	
FP402 (M)	27.8	20.6	25.8	18.7	26.0	19.0	25.0	18.0	15.2	14.0	12.4	4.0	75	733	1,152	2.7:1	
<b>TRADITIONAL FLIPAKS</b>																	
FP03	11.8	9.8	9.3	7.0	10.1	7.8	8.7	6.4	7.7	6.5	2.1	0.3	70	230	9,000	2.8:1	
FP06	15.2	10.9	12.8	7.8	13.8	8.9	12.2	7.3	9.7	8.8	3.0	0.6	70	400	6,720	4.0:1	
FP07	21.8	15.1	18.9	13.7	19.8	14.2	18.8	13.2	5.5	4.6	4.8	0.7	70	250	4,800	3.6:1	
FP075	19.7	11.8	16.9	9.3	17.7	10.1	16.2	8.6	7.3	6.0	3.4	0.7	70	460	5,400	3.0:1	
FP08	20.6	13.2	17.7	11.0	19.0	11.9	17.9	11.4	6.5	5.5	5.2	0.8	75	250	5,040	2.1:1	
FP13	20.6	13.2	17.7	11.0	19.0	11.9	17.0	10.4	11.6	10.5	5.9	1.4	75	250	4,200	4.4:1	
FP141	21.8	15.2	19.1	13.5	20.1	14.2	18.5	12.9	9.8	8.7	5.6	1.4	70	500	3,360	4.4:1	
FP145	21.8	16.0	19.1	13.4	19.9	14.3	18.5	12.8	9.3	8.3	5.6	1.5	70	250	3,000	4.5:1	
FP15	22.3	13.0	19.1	10.9	20.1	11.4	18.9	10.1	12.8	12.5	6.2	1.6	70	250	2,880	3.8:1	
FP181	21.8	15.2	18.6	12.9	19.8	14.0	18.1	12.3	12.9	11.8	6.2	1.8	70	460	2,800	4.0:1	
FP19	23.5	15.7	19.9	13.0	21.0	14.2	19.2	12.4	13.0	11.7	6.9	1.7	75	430	2,800	4.5:1	
FP20	27.0	17.1	24.6	14.8	25.3	15.5	24.4	15.4	10.2	9.0	6.6	2.0	70	550	2,200	3.3:1	
FP241	26.9	17.1	24.3	14.6	25.3	15.5	23.4	13.9	12.6	11.5	7.7	2.4	70	460	2,200	4.2:1	
FP261	23.9	19.6	21.1	17.1	22.2	18.2	20.6	16.5	12.6	11.5	8.4	2.7	70	250	2,400	5.3:1	
FP30	28.0	20.6	25.0	18.0	26.0	19.0	24.7	17.8	12.5	11.0	10.0	3.2	75	250	1,760	3.5:1	
FPST30	28.0	20.6	25.0	18.0	26.0	19.0	24.7	17.8	12.5	11.0	10.0	3.2	75	250	1,760	3.5:1	
FP32	39.0	14.0	36.3	11.3	37.5	12.5	36.0	11.0	13.0	12.1	10.4	3.3	70	250	1,440	4.9:1	
FP38	32.0	18.0	28.8	15.9	30.0	16.6	27.3	14.7	14.9	13.8	11.0	3.8	75	250	990	3.0:1	
FP40	27.6	20.6	25.8	18.7	26.0	19.0	25.0	19.0	15.6	14.0	12.7	4.2	75	530	1,114	2.7:1	
FP60	30.0	22.0	27.4	19.4	28.0	20.8	26.7	18.7	20.5	18.8	17.0	6.1	75	300	400	4.0:1	

### COMPATIBLE PALLET (21 X 15 Flipaks ONLY)

Model	Dimensions		Height Deck	Weight w/Lip (lb.)	Nest Ratio	Fork Truck Entry	Hand Truck Entry	Load Capacity (lb.)		Truckload Quantity		
	L	W						Static	Dynamic	48' Trailer	53' Trailer	
45x48-C SBRR CISF LPI (winboard lip)	48.8	45.7	5.8	6.8	37.0	2.1:1	4 way	4 way	30,000	4,000	840	910

(P) = Plastic Hinge (M) = Metal Hinge All dimensions in inches, unless otherwise specified.

# New Generation Flipak® Family - Important Redesign on 5 Sizes

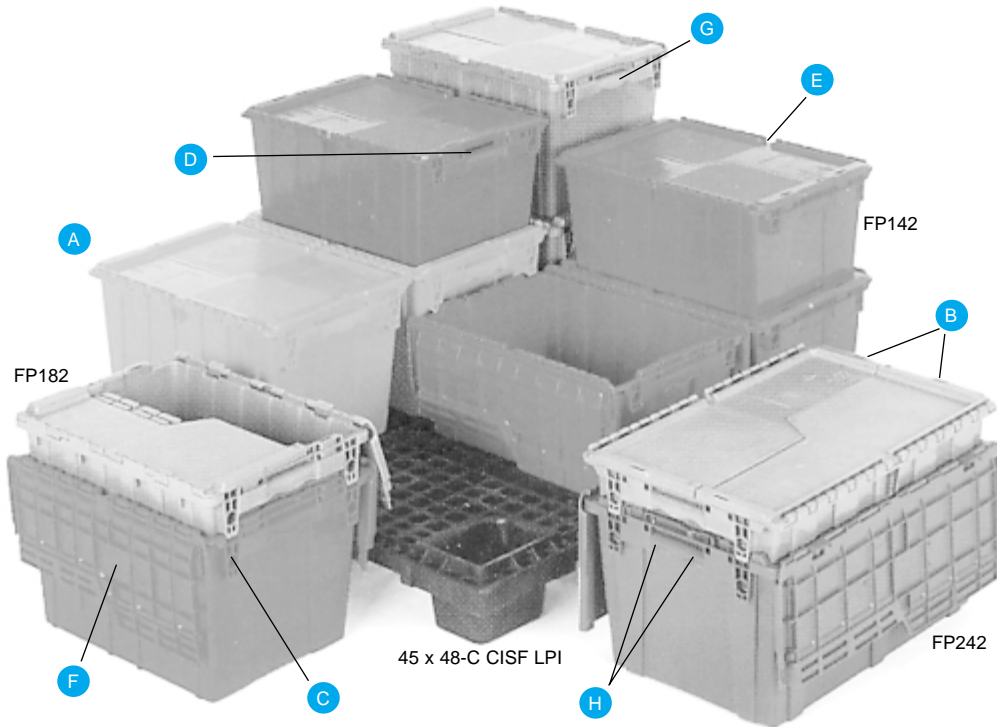

## FEATURES (New Generation)

- A. New plastic hinge element available
- B. Automation compatible with lifting slots
- C. Protected area for radio frequency chips
- D. Optional document slot available
- E. Interrupted hinge for ease of banding
- F. Added interior label area on inside of cover
- G. Improved pocket handles for easy lifting
- H. Drain holes in handles for washing

## FEATURES (All Flipaks®)

- 1/4" or 3/8" diameter reinforced security holes are compatible with a variety of tote closures, from ties to padlocks
- Visible areas above the nest stops for easy reading of sequential numbers or bar codes when nested or stacked
- Cover recessed within perimeter of the container to protect against cover breakage
- Quick release label area on attached hinged cover and container ends for easy reading and quick label change
- Closed pocket handgrips limit product loss and provide convenient grasp and release

## PRE-ENGINEERED IDENTIFICATION OPTIONS\*

**HOT STAMPING** (available in White, Black, Blue, Red, Yellow, Green, Orange)

Loose Letter

1 message, 1 location .....	[CALL]
1 message, 2 locations .....	[CALL]
2 messages, 1 location each .....	[CALL]

Sequential Numbering

Stamp on 1 end.....	[CALL]
Stamp identical on both (2) ends .....	[CALL]

**SPRING STEEL CLIP**

Spring Steel Clip.....	[CALL]
Mounting Charge .....	[CALL]

**SNAPS**

Install One Snap (one end) .....	[CALL]
Install Two Snaps (two ends) .....	[CALL]

**\*\*SET-UP CHARGE:** [CALL] for the application of options/accessories on quantities of 150 or less (per container model and per option/accessory). All options and accessories require additional production time.

Model	STOCK COLORS AVAILABLE					PRICE/EA. BY QUANTITY				
	Gray	Dark Blue	Red	Med. Green	Clear	1-49	50-99	100-249	250-499	
<b>NEW GENERATION FLIPAKS</b>										
FP102 (P)	X					[CALL]	[CALL]	[CALL]	[CALL]	
FP142 (M)	X	X	X			[CALL]	[CALL]	[CALL]	[CALL]	
FP142 (CLM)					X	[CALL]	[CALL]	[CALL]	[CALL]	
FP182 (M)	X	X	X			[CALL]	[CALL]	[CALL]	[CALL]	
FP182 (CLM)					X	[CALL]	[CALL]	[CALL]	[CALL]	
FP242 (M)	X	X	X	X		[CALL]	[CALL]	[CALL]	[CALL]	
FP242 (CLM)					X	[CALL]	[CALL]	[CALL]	[CALL]	
FP402 (M)	X	X	X			[CALL]	[CALL]	[CALL]	[CALL]	
<b>TRADITIONAL FLIPAKS</b>										
FP03	X	X			**	[CALL]	[CALL]	[CALL]	[CALL]	
FP06	X	X			**	[CALL]	[CALL]	[CALL]	[CALL]	
FP07	X					[CALL]	[CALL]	[CALL]	[CALL]	
FP075	X	X				[CALL]	[CALL]	[CALL]	[CALL]	
FP08	X					[CALL]	[CALL]	[CALL]	[CALL]	
FP13	X					[CALL]	[CALL]	[CALL]	[CALL]	
FP141	CALL TED THORSEN FOR PRICING					---	---	---	---	
FP145	X					[CALL]	[CALL]	[CALL]	[CALL]	
FP15	X	X				[CALL]	[CALL]	[CALL]	[CALL]	
FP181	CALL TED THORSEN FOR PRICING					---	---	---	---	
FP19	X		X			[CALL]	[CALL]	[CALL]	[CALL]	
FP20	X	X	X			[CALL]	[CALL]	[CALL]	[CALL]	
FP241	X	X	X		CALL TED THORSEN FOR PRICING	---	---	---	---	
FP261	X					[CALL]	[CALL]	[CALL]	[CALL]	
FP30	X					[CALL]	[CALL]	[CALL]	[CALL]	
FPST30	X	CALL TED THORSEN FOR PRICING				---	---	---	---	
FP32	X					[CALL]	[CALL]	[CALL]	[CALL]	
FP38	X					[CALL]	[CALL]	[CALL]	[CALL]	
FP40	X	X	X		CALL TED THORSEN FOR PRICING	---	---	---	---	
FP60	X					[CALL]	[CALL]	[CALL]	[CALL]	

## COMPATIBLE PALLET (21 X 15 Flipaks ONLY)

Model	PRICE/EA. BY QUANTITY			
	1-19	20-49	50-249	250+
45x48-C SBRR CISF LPI (winboard lip)	[CALL]	[CALL]	[CALL]	[CALL]