

# Ted Thorsen Introduces GRITWORKS!™

GRITWORKS!™ is a line of slip-resistant anti-fatigue mats designed for very demanding situations.

You've heard the statistics: 11.7% of all non-fatal, lost time injuries are slip and fall accidents occurring on the same level. Each incident of this type costs an average of \$28,000.00. That is a lot of money and too much down-time.

Now you can have both safety and comfort with our new GRITWORKS!™ mats. They are designed to combat slip and fall accidents in hazardous industrial areas and commercial kitchens.

All GRITWORKS!™ mats provide extra traction in wet, greasy and oily areas. Each has a coefficient of friction much higher than ADA or OSHA specifications: Dry COF of .75 to .80, Wet COF of .72.

## Modular GRITWORKS!™ No. 483 (Open Tiles)

Modular GRITWORKS!™ No. 483 easily prevents slip and fall problems in wet, greasy and oily areas.

Designed to provide comfort and reduce standing worker fatigue, modular GRITWORKS!™ is a manageable 3' x 3' workstation size. Yet our patented interlocking system requires no attachment devices or additional bevels so these mats can be used to create virtually any configuration.

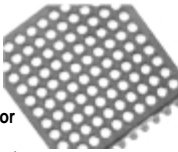

Modular GRITWORKS!™ is easy to clean... simply hose off.

Grease-Proof Grit 1	Weight	Stock Size	Price
30903	12 lbs.	3' x 3'	[CALL]
Grease-Resistant Grit 1	Weight	Stock Size	Price
30906	12 lbs.	3' x 3'	[CALL]



## Diamond-Plate GRITWORKS!™ No. 484 (Closed Tiles)

For use as a single workstation mat, to cover an entire floor, or to create a long runner, these mats easily snap together to form virtually any configuration. Plus, our proprietary built-in interlocking system requires no connectors or additional bevels.

It also interlocks with Modular GRITWORKS!™ to form matting with and without drainage areas. Mats are 1/2" thick with rounded corners.

Grease-Proof Grit 1	Weight	Stock Size	Price
30918	12 lbs.	3' x 3'	[CALL]
Grease-Resistant Grit 1	Weight	Stock Size	Price
30921	12 lbs.	3' x 3'	[CALL]

## Industrial GRITWORKS!™ No. 487 (Open Mats)

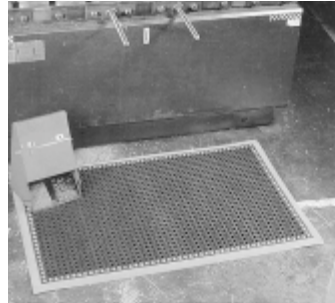

Industrial GRITWORKS!™ No. 487 is designed for heavy duty industrial applications. This 7/8" thick rubber compound is very flexible and provides exceptional comfort while reducing standing worker fatigue. Industrial GRITWORKS!™ is available in a wide variety of workstation sizes. We can also make large custom sizes and unusual configurations. Industrial GRITWORKS!™ is easy to clean... just hose it off.

Black w/Orange Grit 1	Weight	Stock Size	Price	Black w/Yellow Grit 1	Price
31011	17 lbs.	28" x 40"	[CALL]	31014	[CALL]
31023	34 lbs.	40" x 52"	[CALL]	31026	[CALL]
31035	52 lbs.	40" x 64"	[CALL]	31038	[CALL]
31047	84 lbs.	40" x 124"	[CALL]	31050	[CALL]
Black w/Orange or Black Grit 1	Weight	Custom Size	Price	Black w/Yellow Grit 1	Price
31059 - 31220	N/A	Up to 12'W x up to 30'L	Quoted Upon Request	31062	Quoted Upon Request

# Important New Anti Fatigue Mats for Today's Sensitive Electronic and Electrical Equipment Areas

• Additional ESD Matting is also available... Call Ted Thorsen for pricing.

## Electrically Conductive Anti-Fatigue Matting No. 786

Protects workers from fatigue and electronic equipment from damage.

Uses: Areas Where Electro-Static Discharge Can Harm Facilities and Electronic Equipment.

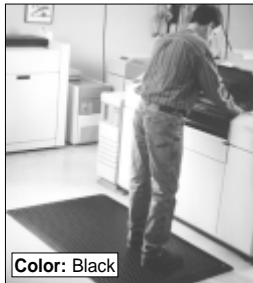

Color: Black

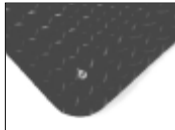

Ground cord snap connection (shown at left).

**Prices**  
3' x 5' Standard Mat [CALL]  
Runners 3' wide up to 75' long - cut to size - [CALL]

- The surface drains static electricity off the worker before it is discharged onto sensitive equipment.
- Sponge base provides superb cushioning support to ease back and leg stress and fatigue.
- Overall thickness 1/2", beveled edges.
- Diamond-Plate and Smooth surfaces.
- Resistivity
  - Smooth Surface: Surface to Surface 4 x 10<sup>6</sup> ohm. Surface to Ground 4 x 10<sup>4</sup> ohm.
  - Diamond-Plate: Surface to surface 10<sup>6</sup> ohm Surface to ground 20<sup>6</sup> ohm.

### Accessories

- \*15' long Ground Cord w/Snap and 1 Clip, 1 Megaohm Resistor [CALL]
- 6' Long Coiled Wire Super Comfort Wrist Strap, 1 Megaohm Resistor [CALL]

## Electrically Conductive Interlock No. 787



Color: Black

A comfortable, economical, reliable, versatile, electrically conductive interlock.

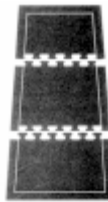

Reliable and economical protection from static discharge.

- Electrically Conductive interlock has exceptional resistivity: Surface to surface - 10<sup>4</sup> ohm. Surface to ground - 10<sup>4</sup> ohm.
- Specially compounded 1/2" thick rubber is electrically conductive throughout.
- Engineered with buoyant air pockets underneath to create a very comfortable work surface. Greatly reduces fatigue and other aches and pains related to standing.
- Sections easily "lock" together to create runners of virtually any size. Also available in singles for individual workstations.
- Economically priced, yet has the qualities of much more expensive products.
- High-Tech deck plate surface is easy to clean and provides additional traction in heavily trafficked areas.
- Edges are beveled for safe, easy access.

Stock Size: 3'W x 2'L Ends, Singles, Centers Price: [CALL] for all styles.

## NEW! Static Dissipative Anti-Fatigue Matting No. 791

OUR BEST - STATIC DISSIPATIVE

Prevents fatigue while protecting components from damaging static electrical shocks.



- Use in any areas where static discharge can harm materials; packaging and storage of electronic components.
- Drains static electricity from workers before it disrupts sensitive equipment.
- Relieves employee fatigue.
- Sponge base reduces stress on the spine and lower back

- Vinyl surface has slip resistant texture.
- Excellent resistivity: Surface to ground 1 x 10<sup>7</sup> ohm. Surface to surface 1 x 10<sup>7</sup> ohm.
- For maximum effectiveness, ground every 10' to 15'. (Call TT for available ground cords.)
- Available in Gray.
- 1/2" overall thickness, edges beveled for safety.

Custom Sizes	Price
3' wide up to 75' in length	[CALL]/lin ft.
4' wide up to 75' in length	[CALL]/lin. ft.
2' x 3'	[CALL]
3' x 5'	[CALL]

# Add-A-Level™ Plastic Modular Flooring Systems

- Stackable • Portable • Optional Anti-Fatigue Mat Top • Match Worker Height to the Job

## WORK PLATFORMS

- Adjustable Height • Modular • All Plastic
- Modular design permits hundreds of floor plans.
- Assemble to desired height, length, or width, using patent pending "Stacker" & "Poly-Clip" system to fit any floor plan.
- Flow through grid permits scrap & liquids to fall or drain below.
- Impervious to oils, gas, acids, & most chemicals
- **No tools required**, snaps together in seconds.
- Replace "unsafe" worn-out platforms & pallets.
- Made from strong, durable, high impact plastic.
- Available with comfort matting & Plug-Lock system.
- Plug-Lock system locks mats to platforms.
- Lightweight for ease in handling.
- Available with ramping system.
- **Temporary or permanent.**

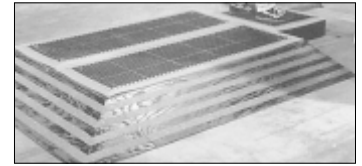

Ramped Base Unit shown here with two 66" x 24" units side by side plus mats.

## Pricing - Modular Plastic Work Platform - Descriptions & Assembly Details

Add-A-Level Platforms 2 1/8" High Per Level				Add-A-Level 1/2" Grease Proof Mat				2 1/8" Comfort Drainage Mat			
Platform	Description	Wt.	Price	Part #	1/2" Thick	Wt.	Price	Part #	2 1/8" Thick	Wt.	Price
A3624B	36x24" Base Unit	11.5	[CALL]	M23120	Black Mat	9.5	[CALL]	M23780	Black Mat	17.0	[CALL]
A3624A	36x24" Add-On	11.5	[CALL]	M23124	Orange Brdr.	11.5	[CALL]	M23784	Yellow Brdr.	17.0	[CALL]
A6624B	66x24" Base Unit	20.6	[CALL]	M25120	Black Mat	15.5	[CALL]	M25780	Black Mat	31.0	[CALL]
A6624A	66x24" Add-On	20.6	[CALL]	M25124	Orange Brdr.	18.5	[CALL]	M25784	Yellow Brdr.	31.0	[CALL]
A9624B	96x24" Base Unit	29.2	[CALL]	M28120	Black Mat	21.5	[CALL]	M28780	Black Mat	43.0	[CALL]
A9624A	96x24" Add-On	29.2	[CALL]	M28124	Orange Brdr.	27.0	[CALL]	M28784	Yellow Brdr.	43.0	[CALL]
A9636B	96x36" Base Unit	43.2	[CALL]	M38120	Black Mat	35.0	[CALL]	M38780	Black Mat	64.0	[CALL]
A9636A	96x36" Add-On	43.2	[CALL]	M38124	Orange Brdr.	38.0	[CALL]	M38784	Yellow Brdr.	65.0	[CALL]

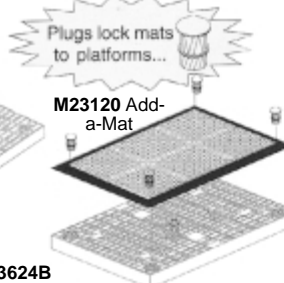
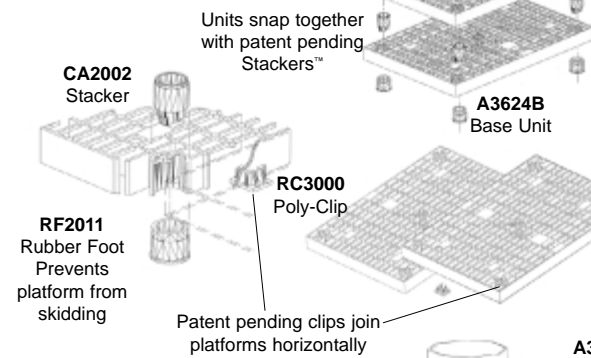

## Add-A-Level Components

Part #	Components	Wt.	Price
R1102	2' x 10" x 2 1/8" Ramp	5.0	[CALL]
R1103	3' x 10" x 2 1/8" Ramp	7.0	[CALL]
R1104	4' x 10" x 2 1/8" Ramp	9.0	[CALL]
R110C	2 1/8" Ramp Corner	5.0	[CALL]
CA2002	Stacker (vertical)	0.2	[CALL]
RC3000	Poly Clip (Horiz.) - (4)	0.2	[CALL]
RF2011	Rubber Foot	0.2	[CALL]
MPL004	Mat Plug Lock (4)	0.2	[CALL]

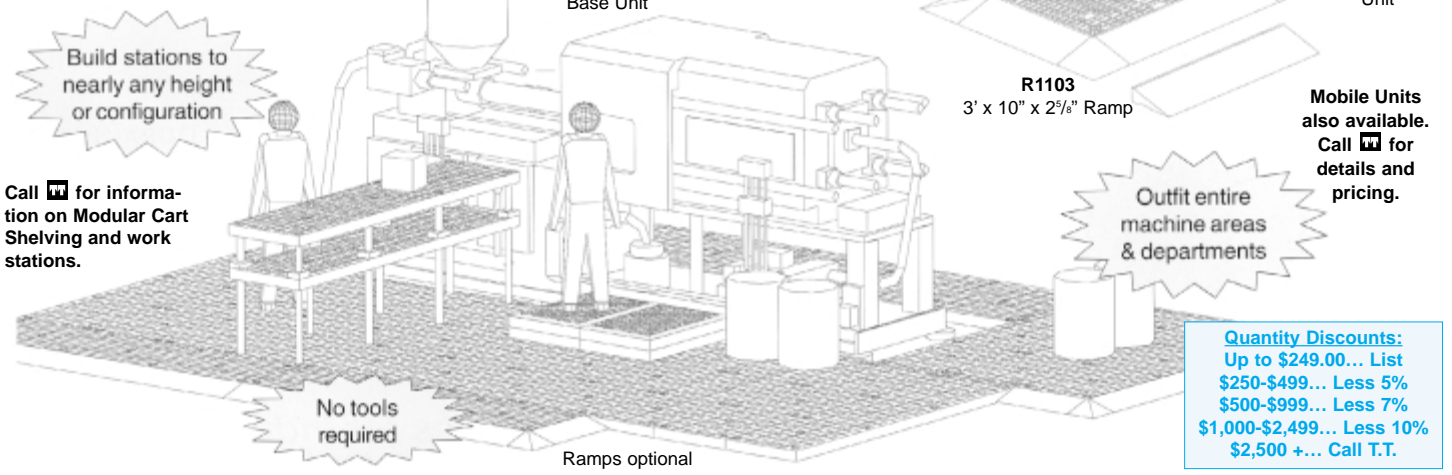

## SAFETY & SECURITY MIRRORS

Prevent accidents and theft with acrylic and glass safety mirrors.

- Eliminate blind spots . . . help prevent collisions
- Mirrors also protect against theft in hi value stock areas.
- Each mirror comes complete with necessary hardware for wall or ceiling mounting.

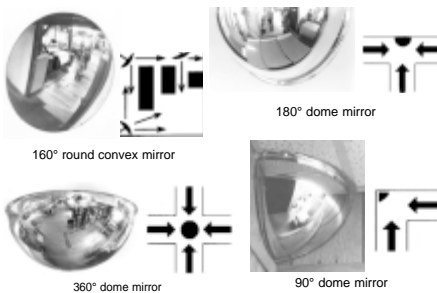

**Convex Mirrors:** Convex mirrors for 160° blind corners. Mounts with an adjustable arm (hardware included). Weatherproofed for years of indoor/outdoor use.

Part No.	Description	Price ea.
CR-13	13" diameter convex glass mirror	[CALL]
CR-18	18" diameter convex glass mirror	[CALL]
CR-26	26" diameter convex glass mirror	[CALL]
PLXR-18	18" diameter convex acrylic mirror	[CALL]
PLXR-26	26" diameter convex acrylic mirror	[CALL]

**Full-Dome Mirrors:** A full 360° of visibility for high-traffic areas at four way intersections.

Part No.	Description	Price ea.
DOME-X-18	18" diameter full-dome acrylic mirror	[CALL]
DOME-X-26	26" diameter full-dome acrylic mirror	[CALL]
DOME-X-32	32" diameter full-dome acrylic mirror	[CALL]

**Half-Dome Mirrors:** 180° of visibility, ideal for three-way intersections.

Part No.	Description	Price ea.
HDOME-18	18" diameter half-dome mirror	[CALL]
HDOME-26	26" diameter half-dome mirror	[CALL]
HDOME-32	32" diameter half-dome mirror	[CALL]

**90° dome mirror:** Ideal for small areas, hallways or elevators.

- Use at "L" shaped intersections where 2-way viewing is needed.
- Helps eliminate blind corners.

Part No.	Description	Price ea.
QDOME-18	18" diameter quarter-dome	[CALL]
QDOME-26	26" diameter quarter-dome	[CALL]

# TT Features Orthopedic Back Supports

An industry standard for well designed products to protect your employees backs. PrevCare back supports feature patented Contour Designs for bending comfort and Sta-Put™ belt loops to prevent “ride up”. Designed to meet demanding medical standards for consistent correct fit, hygiene, comfort and durability. All manufactured in the USA with American made materials. Machine washable.



## The PrevCare® 6000

Designed for heavy-duty use all day and for workers with previous back injuries. 9" solid elastic back; 6" front; patented Sta-Put™ belt loops permit wearing without suspenders. Five stays plus semi-rigid removable back insert for additional support and warmth. Sizes: S, M, L, XL. Standard colors: Black, White, Navy.



Sta-Put® belt loops—slide your slacks' belt through these interior belt loops for a custom fit to prevent belt ride-up.



**Product Number & Pricing:**  
401-6000 (with suspenders) - \$43.95 ea.  
Size: See chart Color: Black, Navy

Sizes	Waist Inches	Centimeters
XS	28"-32"	71-81 cm
S	32"-36"	81-91 cm
M	36"-40"	91-101 cm
L	40"-44"	101-111 cm
XL	44"-48"	111-122 cm
XXL	48"-52"	122-133 cm

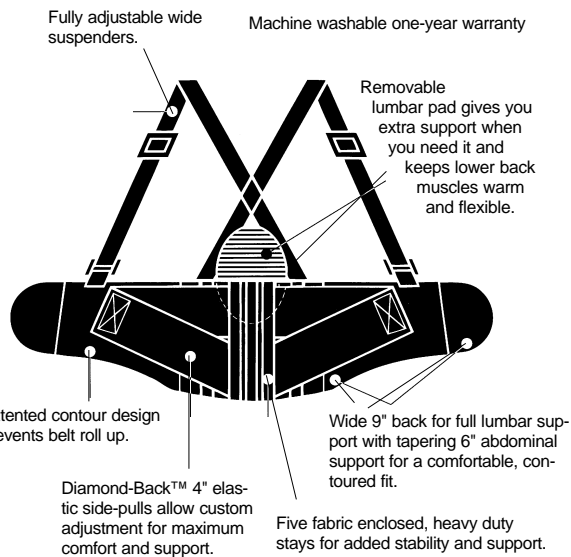

## The PrevCare® 5000

Most popular support, features four stays. Powernet elastic and Diamond-Back™ design. For moderate to heavy-duty lifting all day. Patented Sta-Put™ belt loops permit wearing without suspenders plus four internal gripper strips prevent ride up. Sizes: S, M, L, XL. Standard Colors: Black, White, Navy



Sta-Put® belt loops—slide your slacks' belt through these interior belt loops for a custom fit to prevent belt ride-up.

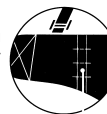

**Product Number & Pricing:**  
401-5000 (with suspenders) - \$[CALL]  
401-5001 (without suspenders) - \$[CALL]  
Size: See chart Color: Black, Navy, White

Sizes	Waist Inches	Centimeters
XS	28"-32"	71-81 cm
S	32"-36"	81-91 cm
M	36"-40"	91-101 cm
L	40"-44"	101-111 cm
XL	44"-48"	111-122 cm
XXL	48"-52"	122-133 cm

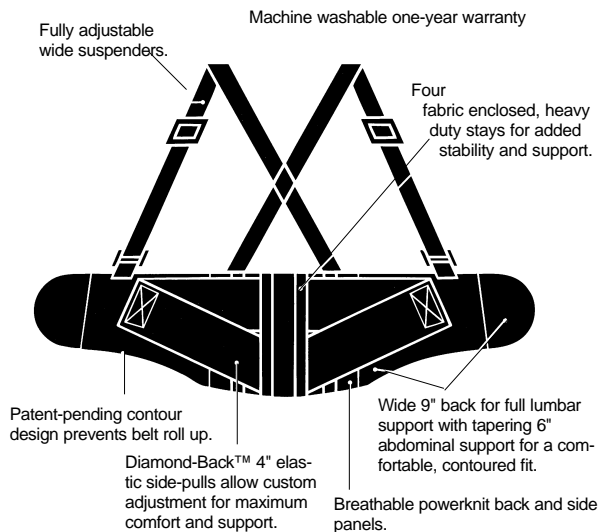

## The PrevCare® 4000

Cool and comfortable support for light to moderate lifting. Ventilated 8" elastic back; 5" front. Patented Sta-Put™ belt loops help prevent support ride-up. Four medical grade stays. Suspenders included.

**Product Number & Pricing:**  
401-4000 (with suspenders) \$[CALL]  
401-4001 (without suspenders) \$[CALL]

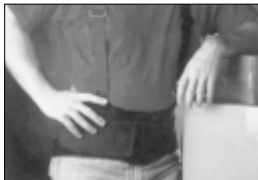

Sta-Put® belt loops—slide your slacks' belt through these interior belt loops for a custom fit to prevent belt ride-up.

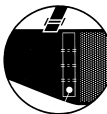

Size: See chart Color: Black, Navy

Sizes	Waist Inches	Centimeters
S	28"-36"	71-91 cm
M	36"-44"	91-111 cm
L	44"-52"	111-132 cm
XL	52"-60"	132-152 cm

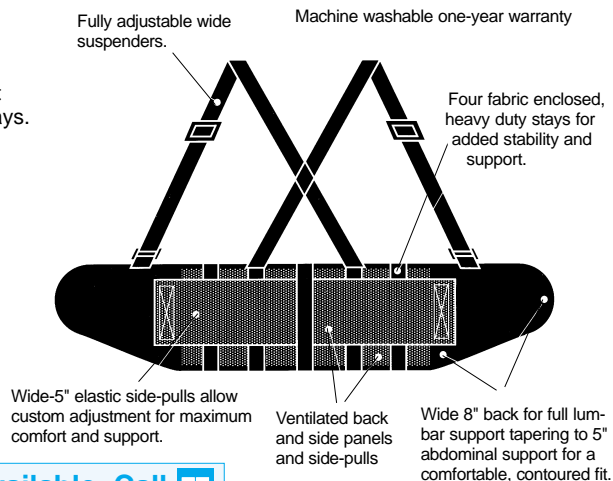

Quantity Discounts Available. Call 



# Ergonomic Wrist Supports

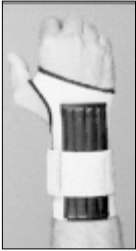

## Ambiflex™ Series 150 Help Prevent Carpal Tunnel Syndrome

Carpal Tunnel Syndrome has been identified as a major challenge in the sewing industry and other manufacturing and clerical repetitive task environments. But this cumulative trauma disorder can often be prevented. Now you can help protect employees from the damaging, repetitive wrist and hand movements their jobs demand.

Ambiflex™ Wrist Support offers proven, low cost protection against soaring Workers' Compensation claims, insurance premiums and absenteeism.

### Features:

- Ambidextrous design fits either right or left hand
- Lightweight, slim profile, and comfortable to wear
- Eight medical grade stays support and encourage wrist to maintain safe neutral position
- Ultrilure™ lining ensures that hands and wrist stay dry
- Adjustable hook and loop closure provides precise, custom fit
- Treated with Engarde™ for bacteria and odor control
- Machine washable



**SIZE:** S, M, L, XL **COLOR:** Black, Tan/Navvy  
**PRODUCT NUMBER:** 400-150 **PRICE:** \$[CALL]

Also available in neoprene with lycra lining #160PS - \$[CALL]

### AMBIFLEX™ SERIES 150 SIZING INSTRUCTIONS

To determine correct size, measure around the hand at widest part of the palm.

SIZE	INCHES	CENTIMETERS
X-Small	6" - 7"	15.24cm-17.78cm
Small	7" - 8"	17.78cm-20.32cm
Medium	8" - 9"	20.32cm-22.86cm
Large	9" - 10"	22.86cm-25.4cm
X-Large	10" - 11"	25.4cm-27.94cm



## Ambiband Series 650

Ambidextrous band stabilizes and supports the wrist. Elastic is fully adjustable with hook and loop closure.

**SIZE:** One size fits all

**COLOR:** Black, White, Navy

**PRODUCT NUMBER & PRICING:**  
400-650 (with thumb loop) - \$[CALL]  
400-772 (without thumb loop) - \$[CALL]



## Ambiwrap Series 775

Helps maintain neutral position and provides support and compression. Comfortable neoprene allows full hand and finger dexterity. Ambidextrous.

**SIZE:** One size fits all

**COLOR:** Black, Tan

**PRODUCT NUMBER:** 400-775  
**PRICE:** \$[CALL]

# LIFTING GLOVE



## PrevCare® Lifting Glove Series 540

Protect your hands from rough edges while lifting. Open finger design features leather palm with pad for maximum protection. Open mesh back allows for cool comfortable fit. Available in pairs only.

**SIZE:** S, M, L, XL

**COLOR:** Black

**PRODUCT NUMBER:** 600-540

**PRICE:** \$[CALL]



## Protoc Plastic Cap Knee Pad Series 300

Maximum protection from ABS cap, resists heavy abrasion from harsh compounds and surfaces. Contoured foam pad, durable fabric covering and two wide, adjustable Velcro™ straps for all-day comfort. One size fits all.

**COLOR:** Black

**PRODUCT #:** 600-300

**PRICE:** \$[CALL]



# Orthopedic Foot Protection

## ProStep™ Full Insoles

Reduce lower back, knee, ankle and foot pain by providing extra impact absorption qualities to the feet. Viscomer™ visco-elastic polymer provides the most effective and durable solution. Hypo-allergenic. Washable. Sold in pairs.

**SIZE:** See chart **COLOR:** Grey only

**PRODUCT NUMBER:** See chart

**PRICES:** PER PAIR: \$[CALL]  
PER CARTON/10: \$[CALL] PER CASE/30: \$[CALL]



# POSTURE & SUPPORT CUSHIONS

EXCELLENT FOR MACHINE OPERATORS AND CLERICAL PERSONNEL



## ContourCare Backrest Cushion Series 295

Designed by healthcare professionals for lower back support while sitting; zippered, washable cover. Colors: Navy, Grey, Burgundy.

**PRICE:** \$[CALL]



## ContourCare Butterfly Posture Cushion Series 296

14" width for both lateral, and vertical full-back support; zippered, washable cover; 34" ties. Colors: Navy, Grey, Burgundy.

**PRICE:** \$[CALL]

## Protoc Knee Pad Series 400

Flexible rubber caps that resist abrasion. Light weight contoured foam covered with durable fabric protects sensitive knee joints. Two wide, adjustable Velcro straps for wearer comfort. One size fits all.

**COLOR:** Navy

**PRODUCT NUMBER:** 600-400

**PRICE:** \$[CALL]

## English or Spanish

### "It's Your Back" Video

"Must" viewing for all employees who lift or load.

This professional 15-minute video for employee viewing and training demonstrates, in detail, proper body mechanics and lifting techniques. It provides an explanation of how the spine works and how it can be stressed at work or at home and the impact back injuries can have on daily living.

**Product #:** 789-56000 **Price:** \$[CALL]

**Product #:** 789-56000S (Spanish) **Price:** \$[CALL]



# CATALOG #2010 INDEX

- AIR FLOAT, CASTERS 349
- AIR LIFTS/GRABBERS 240,418
- ANTI-FATIGUE MATS 435-442
- ASSEMBLY BENCHES 376-386
- ASSEMBLY SHELVING 229
- BAGS
  - BAG HOLDERS 247
  - BAGGING JACKS 331
  - BULK 209
  - CUTWORK 209
- BALL TRANSFERS 182
- BALL TRANSFERS, RETRACTABLE 182
- BARREL TRUCKS 343
- BARRELS, PLASTIC 51
- BASKETS
  - CANVAS 245-248
  - DISPLAY 146
  - PARTS WASHING 127
  - WIRE 145-146
- BENCHES
  - ADJUSTABLE 387
  - ASSEMBLY 387, 389
  - BUNDLE 254
  - COMPONENTS 391-392
  - LEGS 391-392
  - MOBILE 290, 386
  - PACKING 377-390
  - PEDESTAL, DRAWER 384
  - RISERS 388
  - SECURE 384
  - SPECIAL 387, 389
  - TOPS 393-394
  - TOPS, MAPLE 392
  - TOPS, ESD 393
  - WORK-AID 254
- BIG PAKS 1-15
- BINS
  - ACCESSORIES 171-172
  - BULK 37
  - CORRUGATED 166
  - CURVED 150
  - DRAWER, PLASTIC 162
  - ESD 136-138
  - FIBERGLASS 147
  - FIBRE AND PLASTIC 159
  - FLOW CONTROL 151
  - GIANT 150, 161
  - HEAVY DUTY 128
  - METAL 151, 175, 177-178
  - MOBILE 148
  - MODULAR 151
  - MULTIPLE, SLIDING 161
  - PALLETS 38
  - PARTS 32,136-138,171, 174-178
  - PLASTIC 143, 148-150, 152-158, 161
  - 171-173
- ROTARY 148
  - SHELF 171
  - STACK/NEST 147-150, 160
  - STACKING 147, 177-178
  - STEEL 148
  - STORAGE 147
- BOXES
  - BULK 18-31,37.
  - CLEAR 167
  - CORRUGATED, PALLET 16
  - DROP BOTTOM 34
  - ESD 107-110, 131-138
  - GRAVITY FLOW 31
  - PALLET 1-15,18,32
  - PALLET, DROP BOTTOM 31
  - PALLET, MESH 34
  - PALLET, PLASTIC 15,24-26,38,
  - PALLET, NESTABLE 38,
  - PALLET, STACKABLE 15,38,
  - PALLET, STORAGE 15-16
  - PLASTIC, DIVIDED 167
  - PLASTIC, STACKABLE 19-25, 27, 38-40
  - PLASTIC, STORAGE 15-16
  - SMALL PARTS 148-178
  - SMALL, CLEAR 138, 151, 167, 172, 184
  - STEEL PALLET 33-34
  - STEEL, PALLET, COLLAPSIBLE 34
  - STEEL, STACKING 32-34
- BUMPERS, CART 353
- BUNDLE TIES, REUSABLE 251
- CABINETS
  - BIN 159, 163-165
  - BIN, ESD 137
  - BOX 167
- DATA 371
- DOOR 371
- DOOR MOUNT 163-165
- GAS CYLINDER 345
- HAZMAT 345
- PARTS 175-176, 236
- PLASTIC 172-173
- SECURITY 270-271
- SHELF 372
- STORAGE 372
- TOOL 163-164
- WINDOW 371
- CARDHOLDERS, TOTE 116, 118, 120-121, 126, 132, 233-235, 331
- CARGO RESTRAINTS 35-37
- CAROUSELS, FABRIC, VERTICAL 241
- CAROUSELS, PALLET 420
- CARRIERS, CLOTH, COLLAPSIBLE, TROLLY 208-209
- CARRIERS, WIRE, COLLAPSIBLE, TROLLY 208
- CARTS
  - ADJUSTABLE 326-327
  - ADJUSTABLE SHELF 317, 322, 326-327
  - 259-262, 266
  - ADJUSTABLE/TILT 252
  - ALUMINUM 286, 333
  - BASKET 286
  - BIN, MOBILE 159
  - BUNDLE 253
  - EXAMINERS 305
  - FIBERGLASS 340
  - FIBERGLASS, SELF LEVELING 57
  - FILE 286
  - FLOW RAIL 180-181
  - INSTRUMENT 304
  - LEVELING 252, 315-316
  - MAIL 286
  - MESH 249
  - PICKING 282, 289-294, 304
  - PLASTIC 292-293
  - PLATFORM 286, 304
  - PRODUCTION 328
  - SCALE 58
  - SECURITY 53, 270, 290, 300, 318, 321-322
  - SERVICE 282, 286, 289-294
  - SHELF, ADJUSTABLE 267-268
  - SHELF, PLASTIC 267-268
  - SHELF, SLANTED 160, 253
  - SPECIAL 257-258
  - TILT 249, 333-340
  - TOTE 160, 252, 328
  - TOTE/TRAY 131
  - UTILITY 333-334
  - WASTE 333-338
  - WIRE SHELF 259, 326-328
  - WOOD TOP 257
  - WORK IN PROCESS 252
  - WORK-AID 252, 255-258
- CASTERS 350-351
  - BALL 350
  - LOCKING 355
  - PNEUMATIC 351, 354
  - STEM 350, 353-354
  - TABLE 352
  - THREAD GUARD 350, 352
- CHAIN HOISTS 411
- CHAIR ACCESSORIES 433
- CHAIRS, ERGONOMIC 425-432, 434
- CHAIRS, FACTORY 425-432, 434
- CHAIRS, METAL 428
- CHAIRS, PLYWOOD SEAT 428
- CIRCUIT BOARD HOLDER 133, 135
- CLAMP TRUCKS 256-257, 259
- CLAMPS, PIPE 199-200
- CLAMPS, TUBING 202
- CLEAN UP CARTS 342-344
- CLOTH BAR CONES 243
- CLOTH BARS 243
- COMPUTER ARMS 308
- COMPUTER STATION, SECURE 307-308
- CONTAINERS
  - CONTAINERS, COLLAPSIBLE 19-23,37,
  - EXTRA LARGE 21
  - EXTRA TALL 21
  - NESTING, PLASTIC 9-15, 83-105
  - PALLET 37-40
  - PALLET, NESTABLE 38-40
  - PALLET, PLASTIC 65-77
  - PARTS WASHING 46
  - PLASTIC 9-15,17-18,20-23
  - PLASTIC, BULK 55-56
- PLASTIC, INSULATED 18.
- PLASTIC, PALLET 19-23
- PLASTIC, SECURITY 8-17, 83-89
- PLASTIC/STAINLESS 127
- REFUSE 339, 341
- REUSABLE, SHIPPING 1-15.
- SHIPPING 61, 210
- STACKABLE 19-30,38-40
- WASTE 339, 341
- WIRE, COLLAPSIBLE 41-44
- WIRE, MOBILE 41-45
- WIRE, PALLET 41-47
- WIRE, SPECIAL PURPOSE 46
- CONVEYORS
  - ACCESSORIES 195
  - BALL TRANSFER 180-181
  - BELT 191-195
  - EXPANDABLE, POWER 188, 190-191, 206
  - EXPANDABLE, ROLLER 189-190
  - FLOW RAIL 183-186
  - FLOW RACK 183, 196
  - GRAVITY 179-181
  - GRAVITY, CROSSOVER 196
  - GRAVITY 179-189
  - INCLINED 192-194
  - MESH, SAFETY 226
  - MOBILE 192-194
  - POWER 192-194
  - ROLLER 179-181
  - SKATE WHEEL 179, 181
  - SPECIAL 193-194
  - STAINLESS 194
  - STANDS 181
  - TRUCK DECK 196
  - VERTICAL 195
- COOLERS, MAN 207
- COVERS, CART/TRUCK 57
- CRANE, FLOOR 402
- CUSHIONS, POSTURE 444
- CUTTERS, PAPER 385
- DECKING
  - PARTICLE BOARD 225
  - RACK 225
  - SPRINKLER 225
  - STEEL 225
  - WIRE MESH 225
- DESKS
  - MOBILE 305
  - SHOP 304
  - STAINLESS 305
  - STAND-UP 305-306, 310
- DIE STORAGE RACKS 232
- DISPENSERS, ROLL GOODS 237
- DISPLAY FIXTURES 211
- DISPLAY, LITERATURE RACKS 161
- DIVIDERS, TOTE
- DOCK BOARDS 369
- DOCK FANS 370
- DOCK LIFTS 417
- DOCK LIGHTS 360-370
- DOCK PLATES 369
- DOCUMENT POCKETS 331
- DOFFING JACKS 239
- DOLLY
  - ADJUSTABLE 253
  - ALUMINUM 312
  - BULK/BOX 27
  - HEAVY DUTY 311
  - MOVERS 312-313
  - PALLET 312, 411
  - PLASTIC 314
  - SPECIAL 312
  - TOTE 311
  - TROLLY 314
  - WOOD 313
- DOOR STRIPS 368
- DRAWER CABINETS, ESD 138
- DRAWER UNIT, PLASTIC PARTS 172
- DRAWER UNITS, MODULAR 174
- DRAWER UNITS, METAL 174-176
- DRAWER UNITS, PLASTIC 174
- DRAWERS, METAL 175-177
- DRAWERS, PARTS 236
- DRUM DOLLIES 311
- DUMPERS, ELECTRIC 338
- DUNNAGE 168
- DUNNAGE, PADS 7
- E-TRACK BELTS 35-36
- EMPLOYEE LOCKERS 372, 374
- ERGONOMIC MATS 436-442
- ESD TOPS 393
- FABRIC LIFTS 241
- FANS, INDUSTRIAL 207
- FIBRE TUBES 238
- FITTINGS, PIPE 199-200
- FITTINGS, RAIL 199-205
- FLAMMABLES STORAGE 345
- FLOOR LOCKS 352-353
- FLOW RACK 180, 183-186
- FOOT RESTS 433
- FORK LIFTS, WALKIE 405-411
- FRAMES, TRUCK CANVAS 248
- GARMENT HANGER ACCESSORIES 211
- GARMENT RACKS 329-332
- GENIE (tm) LIFTS 408
- GLOVES, CARPAL TUNNEL 444
- GLOVES, LIFTING 444
- GRAVITY FLOW RACKS 183-186
- GROUND LIFT/TILTTERS 417, 421
- GROUND LIFTS, SCISSORS LIFTS 417
- HAND PALLET JACKS 403
- HAND TRUCKS 346-348
- HAND TRUCKS, BARREL 343
- HAND TRUCKS, CONVERTIBLE 347
- HAND TRUCKS, SPECIAL 348
- HANG ALLS (tm) RAIL 211
- HANGAR PAKS 11
- HANGERS, CLAMP, WOOD 210
- HANGERS, GARMENT, DISPLAY 209
- HANGERS, GARMENT, OVEN 210
- HANGERS, GARMENT, WIRE 210
- HANGERS, WOOD 210
- HAZARD/SPILL CONTAINERS 342-344
- HEAVY LOAD STORAGE 232
- HOIST KITS, ROLLS 240
- HOOKS, BAG, CONVEYOR 209
- HOPPERS, SELF DUMPING 339
- HORSES, BUNDLE 255
- IN PLANT OFFICES 397-401
- INSERTS/DIVIDERS, TOTE 168
- INSOLES 444
- INTERIOR BUILDINGS 227-228
- JACKS, CLOTH ROLL 239
- JOB SITE STORAGE 374
- LABEL SYSTEM, REMOVEABLE 91
- LABELS 91, 233-234
- LABELS, CONTAINER 30,91
- LABELS, REMOVABLE 233-235
- LABELS, TOTES 119,126
- LADDERS
  - ACCESSORIES 357-361, 363-366
  - ALUMINUM 360, 364
  - CROSSOVER 362, 364
  - DOUBLE END 365
  - EASY CLIMB 359, 362
  - EXTENSION 367
  - FIBERGLASS 367
  - FOLD/ROLL 364
  - FOLDING 367
  - LONG TOP 365
  - MOBILE 358-361, 363-366
  - PLASTIC 355
  - QUICK TURN 362
  - SAFETY 356-361, 363-366
  - STAINLESS 360
  - STOCK PICKING 282, 361
  - TILT TOP 356
  - TILT/ROLL 343
  - WOOD 367
- LETTERS, NUMBERS, SETS 233-234
- LIDS, CONTAINER 38-40
- LIFT, MULTI-PURPOSE 402
- LIFT, ROLL HANDLING 238
- LIFTER/TILTTERS 422
- LIFTS, BARREL 344
- LIFTS, MAN 424
- LIFTS, MANUAL 408, 411
- LIFTS, TANK, ADJUSTABLE 424
- LIFTS/TILT 417, 422
- LIGHTWEIGHT HAND TRUCKS 346-348
- LINERS, POLY, BAG 16
- LINERS, REPLACEMENT 248
- LOCKERS, EMPLOYEES 372-374
- LOCKERS, BOX 372-373
- LOCKERS, PLASTIC 374
- MACHINERY MOVERS 348-349
- MAILROOM EQUIPMENT 286
- MAINTENANCE LIFTS 424
- MAN LIFT PLATFORMS 424
- MAN LIFTS 388
- MATS, ANTI-FATIGUE 435-442
- MATS, ANTI-STATIC 442
- MATS, ESD 441-442
- MATS, EXTRA THICK 437

MATS, GRIT TOP 441  
 MATS, MODULAR 438  
 MATS, STRIP 440  
 MATS, WELDING 438  
 MATS, WET AREA 438-439  
 MATTING 435-442  
 MESH PARTITIONS 399-400, 404  
 MESH ROOMS 399-401, 404  
 METRO MAX (tm) CARTS 267-268  
 METRO MAX (tm) SHELVING 267-268  
 METRO SHELVING 263-266, 269  
 METRO SHELVING ACCESSORIES 264-266  
 MEZZANINES 227-228  
 MOBILE LIFTS 413-415, 419  
 MOBILE SEATS, TOOL/REPAIR 434  
 MODULAR DRAWERS 236  
 OFFICES, IN PLANT 397-401  
 PACKING ACCESSORIES 390  
 PALLETS  
   BOXES 32  
   CONVEYORABLE 65, 69-72  
   DRUM  
   DUNNAGE 73-74  
   HOLD DOWN BELTS 67  
   JACKS, MOTORIZED 404-406  
   JACKS 403, 406  
   METAL 73-74,76-77  
   PLASTIC, RECYCLED 73-76  
   PLASTIC 55,63,65-67,69-73-75,77  
   PLASTIC CONVEYORABLE 65-66,69-72,75  
   PLASTIC, CAPS 67  
   PLASTIC, RACKABLE 65-66,68  
   POSITIONERS 420  
   RACKS 223-224  
   ROLL HANDLING 78-82  
   SLAVE 72  
   SPECIAL SIZE 73-74  
   STACKING, ALL STYLES 78  
   STACKING, PIPE FRAME 82  
   STACKING, REMOVABLE POST 79-80  
   STACKING, STEEL 79-80  
   STACKING, STEEL NEST 81  
   STACKING, ALL STYLES  
   STEEL 33  
   TIERING FRAME 82  
   TOP CAPS 119,126.  
   WOOD FIBRE 72  
 PANEL HOLDERS 274  
 PANELS, LOUVERED 152-158  
 PARTITIONS, FACTORY 399-400, 404  
 PARTS CABINETS 236  
 PARTS WASHING, BASKETS 46, 127  
 PIECE GOODS TRUCKS 244  
 PLATFORM, FORKLIFT 402  
 POLY ERECTA (tm) SHELVING 269  
 PORTABLE OFFICES 397-401  
 POWERED STACKERS 405  
 POWERED TACKERS 406  
 PRY BARS 274  
 RACKS  
   ACCESSORIES 224  
   BIN BOX 147  
   CANTILEVER, STORAGE 229-230  
   CANTILEVER 229-230  
   DISPLAY 145  
   DRYING 142, 145  
   GUARD, MESH 226  
   HAND LOAD 217-221  
   LABELS 233-235  
   PALLET 223-224  
   ROLL OUT 232  
   ROLLING 329-332  
 RAIL COMPONENTS 201-205  
 REPAIR STOOLS 434  
 ROLL DISPENSERS 385  
 ROLL DISPENSERS, FABRIC 241  
 ROLL GOODS CARRIER, CANTILEVERED 242  
 ROLL GOODS UNWINDERS 237  
 ROLL HANDLING 238  
 ROLL INDEXER 238  
 ROLL JACKS 239  
 ROLL RACKS, PAPER 390  
 SAFETY CANS 345  
 SAFETY MESH 226  
 SCALES 148  
   COUNTING 198  
   FACTORY 197-198  
   FLOOR 197-198  
   PORTABLE 197-198  
 SCISSORS LIFTS 413-418, 424  
 SCISSORS LIFTS, CAROUSEL TOP 416, 418  
 SCISSORS LIFTS, TALL 424  
 SEALS, SECURITY 212  
 SEATING, ADJUSTABLE 425-431, 434  
 SEATING, INDUSTRIAL 425-431, 434  
 SECURITY CARTS 270  
 SECURITY SCREENS 399-401, 404  
 SECURITY SEALS 212  
 SECURITY TRUCKS, CANVAS 248  
 SEMI-LIVE SKIDS 278  
 SEWING TABLE EXTENSIONS 395-396  
 SHELVING  
   ASSEMBLY 229  
   PLASTIC 269  
   RIVET BEAM 217-218  
   STEEL 162, 213-216  
   STEEL, "V" GROOVE 231  
   STEEL, DIE STORAGE 231  
   STEEL, REELS 231  
   WIDE SPAN 219-222  
   WIRE 263-266  
 SHOP DESKS 305  
 SIGN HOLDERS, SNAP ON 211, 235  
 SIT-STANDS 433  
 SIZE DIVIDERS, RAIL/GARMENT 211  
 SKID JACKS, HI-LIFT 406-407, 410  
 SKIDS 278  
 SKIDS, SEMI-LIVE 278  
 SLICK RAIL 201-205  
 SLICK RAIL, ACCESSORIES 206  
 SLIDING DRAWER RACKS 232  
 SLOPED SHELVING 229  
 SLOTTED ANGLE 231  
 SMOKERS URNS 341  
 SPAN TRACK (tm) 183-186  
 SPEED RAIL 201-205  
 SPILL CONTAINMENT 342-344  
 SPREADING MACHINES, CLOTH 243  
 SPRING LIFTS 414, 420  
 SPRING PLATFORMS 245-248, 315-316  
 STACKERS, COUNTERWEIGHT 411  
 STACKERS, POWERED 407, 409-410  
 STANDS, BIN 151-158, 171-172  
 STANDS, BIN, LOUVERED 172-173  
 STANDS, BIN, MOBILE 153-157, 172  
 STANDS, BULK BOX 32  
 STANDS, COMPUTER 306, 310  
 STANDS, DOCUMENT/QC 309  
 STANDS, INSPECTION 309  
 STANDS, STEEL 32  
 STANDS, TOTE 45  
 STANDS/STEEL/BULK CONTAINERS 32  
 STEEL SHELVING 213-216  
 STEP STOOLS 366  
 STARYS (tm) CARTS 270  
 STRAPPING 10  
 STRETCH WRAP MACHINE 77, 420  
 STRIP DOORS 368  
 SUPER ERECTA (tm) SHELVING 263-266, 269  
 SWITCHES, SPEED RAIL 204  
 TABLES, ALUMINUM 386  
 TABLES, CUTTING 243  
 TANKS  
   ACCESSORIES 62  
   BULK, STEEL 63-64  
   BULK, STAINLESS 63-64  
   PLASTIC, LIQUID STORAGE 61-64  
   PLASTIC, STORAGE, BULK 61-64  
   STORAGE, BULK 18, 61-64  
 TAPE, LABEL DISPENSERS 385  
 TILTER, GROUND ENTRY 421, 423  
 TILTER/CORNER 423  
 TILTERS 419  
 TILTERS, BENCH TOP 422  
 TILTERS, MOBILE, BOX, SKID 412  
 TILTERS, MOBILE, PALLET 412  
 TOOLBOX, ESD 138  
 TOOLS, STRAPPING 10  
 TOTES  
   ACCESSORIES 83,115  
   ASR 124-125,133  
   CARDHOLDER 120-122,135  
   CLEAR 89,92,113  
   COLLAPSIBLE 113-114  
   CORRUGATED PLASTIC 149, 159, 162  
   CROSS CUBE 119,126,129-130  
   CUSTOM 101-103,111  
   DISTRIBUTION 84-90,92-94  
   DIVIDED 111,115,118,120-124,128,131-135  
   ESD 108,111,131-135  
   FIBERGLASS 109-110  
   FIBRE 103  
   FOOD 129-130  
 GRAVITY FLOW 104  
 HINGE SIDE 113  
 LARGE 112  
 LONG 105,120  
 METAL 177-178  
 NESTING 92,98-106,108,111,128-130  
 PLASTIC, INFORMATION 82  
 PLASTIC, SPLIT LID 83-92, 118-120  
 PLASTIC, STRAIGHT SIDED 113-121, 127  
 131-135.  
 PLASTIC, A.I.A.G.88  
 PLASTIC, ACCESSORIES 17, 83, 116  
 SECURITY 97  
 SOLID FIBRE 159  
 SPECIAL PURPOSE 95  
 SPECIAL 115-117, 125, 149, 162, 168  
 SPLIT-LID 84-90,92,114  
 STACK/NEST 52, 92-98, 100, 104, 106  
 109, 112, 123, 127, 129-130, 143, 149  
 STACKING 107,110,115-124,126  
 STRAIGHT SIDED 84,100,120,126  
 VENTILATED 112,115-118,128-130  
 WATERPOOF 97  
 WIRE MESH 103  
 TQ BUNDLE CARTS 255  
 TRACTION STRIPS, TOTE 97  
 TRAY TRUCKS 141  
 TRAY TRUCKS, K.D. 141  
 TRAYS  
   ALUMINUM 141  
   ASSEMBLY 125, 133-135, 149, 159, 169-170  
   CORRUGATED, PLASTIC 140  
   ESD 108  
   FIBERGLASS 109  
   PLASTIC 108, 141, 169  
   PRINTED CIRCUIT 133-135  
   SMALL PARTS 168-170  
   SPECIAL 169-170  
   TOOL 396  
 TRICYCLES, INDUSTRIAL 355  
 TROLLY  
   BOOSTERS, LIFTS 206  
   CARRIERS, CLOTH, COLLAPSIBLE 208-209  
   CARRIERS, WIRE, COLLAPSIBLE 208  
   HOLDERS, MOBILE 206  
   TRANSFER AIDS 206  
   TRANSPORTER 207, 331  
   SPEED RAIL 205  
 TROUGHS, TABLE 254  
 TRUCKS  
   "A" FRAME 281-283  
   "V" BED 279  
   2 SIDED 299  
   3 SIDED 271  
   5TH WHEEL 275-277  
   ACCESSORIES 144  
   ADJUSTABLE 147, 259-260, 280, 284  
   ALUMINUM 139-141, 287-288, 297  
   BASKET, MESH 249  
   BASKET, STACKING 145-146  
   BIN 291  
   BOX 290  
   BULK 53-54, 271-272, 295, 301  
   BULK, FIBERGLASS 57  
   BUNDLE 255-258  
   BUSHEL 245-247  
   BUSHEL, K.D. 251  
   CAGE 302, 318-326, 374  
   CANVAS..11, 245-248  
   CANVAS, SPECIAL 250  
   CANVAS, K.D. 251  
   CAROUSEL 279  
   CLAMP 256-258  
   CLEAN ROOM 262, 285  
   COMPARTMENT 61, 271-272, 295-296  
   CONVEYOR BED 295  
   CUSTOM 61, 273-274  
   DUNNAGE 61  
   DYE HOUSE 48-52,54  
   ELEVATED 247, 284  
   ELEVATED, MESH 249  
   EMERGENCY 302  
   ERGONOMIC 315-316  
   FIBERGLASS 57  
   FIBERGLASS, BULK 57  
   FIBRE 302  
   FLAT DECK 244, 260, 275-277  
   FOLDING SHELF 322  
   FOLDING 318-326  
   FORK LIFTABLE 323-324  
   HINGED SHELF 300  
   INSTRUMENT 290  
 INTERPLANT 318-326  
 KNOCK DOWN 139-140, 141-142, 259-262  
 303  
 LADDER 282, 287-288  
 LARGE 48  
 LAUNDRY, SHELF 51  
 LEAF 300  
 LIDS 59-60  
 LINERS, PLASTIC 60  
 MESH WIRE 300  
 METRO 261-262  
 NESTING 274  
 PICKING 284, 287-288, 295, 299, 317  
 PIN/COIL 297-298  
 PLASTIC, TEXTILE 316  
 PLASTIC, UTILITY 55  
 PLASTIC..11,17,50,141  
 PLASTIC, BULK 55,58-60  
 PLASTIC, BUSHEL 59-60  
 PLASTIC, DYE HOUSE 47  
 PLASTIC, ELEVATED 58  
 PLASTIC, LARGE 47-48,54  
 PLASTIC, SELF LEVELING 47, 57  
 PLASTIC, W/LID 17  
 PLASTIC, SECURITY 53-54  
 PLATED WIRE 259-260  
 PLATFORM 260, 275-277, 279-285, 295  
 297, 303  
 PRODUCTION 317-326  
 ROLL GOODS 237, 242, 244, 295  
 SEALS 212  
 SECURITY 53, 290, 300, 318, 321-322  
 SELF LEVELING 41, 47, 248, 250-252  
 SERVICE 280, 283, 285, 289-294  
 SHELF 53-54  
 SLIDE 139,141  
 SLIDING TRAY 139-145  
 SLOPE FRONT 245, 247  
 SPECIAL 271-274  
 SPRING LEVELING 41, 47, 248, 250-252,  
 315-316  
 SPRING PLATFORM 41, 47, 248, 250-252,  
 315-316  
 STACKING 118  
 STAINLESS 285, 297  
 STOCK 287-291, 295, 299, 303, 321, 323, 327  
 TEXTILE 47-48  
 TILT 55  
 TOOL 295, 301  
 TOTE BOX 118,139-140  
 TRANSFER 248, 250  
 TRAY 139-141  
 TRAY, SPECIAL PURPOSE 144  
 TRAY, SPRING LEVELING 142  
 TRAY, ADJUSTABLE 142, 259-260, 280, 284  
 UNWINDING 237  
 WAGON 303  
 WIRE, PLATED 261-262  
 WIRE, SHELF 259-260  
 WOOD DECK 275-277  
 WORK-AID 273-274  
 WORK-IN-PROCESS 118  
 YARN 298  
 TUBES, FIBRE 238  
 TUBING, RAIL/STORAGE 201-205  
 UNIT PACKS (1-15)  
 VACUUM LIFTS 240  
 VISUAL CONTROL PRODUCTS 233-235  
 WALK THRU DOORS 368  
 WELDING, PLASTIC, KIT 17  
 WHEELS 352, 354  
 WIDE SPAN STORAGE 217-222  
 WORK AIDS 145  
 WORK BENCH  
   ACCESSORIES 391-392  
   BENCHES 375, 383-386  
   CANVAS 247  
   COMPONENTS 375, 377-382  
   SMALL 254  
   SPECIAL 379  
   TOPS 393  
 WORK PLATFORMS 365  
 WORK STANDS 376  
 WORK STANDS, ADJUSTABLE 376, 401  
 WORK STANDS, ERGONOMIC 401  
 WORK STANDS, MOBILE 362, 376  
 WORK STATIONS 309  
 WORK STATIONS, COMPUTER 306-308, 310  
 WORK TABLE EXTENSIONS 395-396  
 WORK-AIDS 395-396  
 YARN PAKS 7  
 Z RACKS 329-332

