

Counterweight Stackers/Load Conveyors

1000 lbs. Capacity at 13" or 15" Load Center • Manually Propelled
 Battery Lifting Power • 25" or 30" Forks • Counterweights Additional

This smartly engineered lift eliminates the front straddles for complete versatility. Ideal for feeding machinery or lifting to docks and mezzanines where base legs could interfere. This is not a unit that is recommended for moving loads long distances or over uneven surfaces, but a lift that is extremely effective for applications where conventional lifts are impractical.

Model Number	Load Capacity	Raised Height	Lowered Height	Dimensions H x W x L	Wheel Dia. Front/Rear	Shipping Weight	List Price
CW Series - Adjustable 25" Forks - 13" Load Center							
C62	1000 lbs.	62"	1"	80" x 27" x 36"	5" / 5"	570 lbs.	\$(Call)
C74	1000 lbs.	74"	1"	92" x 27" x 36"	5" / 5"	590 lbs.	\$(Call)
CW Series - Adjustable 30" Forks - 15" Load Center							
C62-15	1000 lbs.	62"	1"	80" x 27" x 41"	5" / 5"	570 lbs.	\$(Call)
C74-15	1000 lbs.	74"	1"	92" x 27" x 41"	5" / 5"	590 lbs.	\$(Call)

Overall length on C62 & C74 is 61" and on C62-15 & C74-15 is 71".
 C62-15 & C74-15 must be ordered with a minimum of 600 lbs. of counter weight.

- Features:**
- 1000 lb. capacity
 - 13" & 15" load centers
 - Lifting heights - 62" & 74"
 - Lifting speed 5" per second
 - No outriggers
 - Built-in tapering battery charger
 - Heavy-duty deep cycle battery
 - 25" or 30" solid steel adjustable forks.

No other options permitted on counterweight units.



Lifting Weight	Counter Weight	List Price
1 - 200 lbs.	150 lbs.	\$(Call)
200 - 399 lbs.	300 lbs.	\$(Call)
400 - 599 lbs.	400 lbs.	\$(Call)
600 - 799 lbs.	500 lbs.	\$(Call)
800 - 1000 lbs.	600 lbs.	\$(Call)

Counterweight not included

Model C-74-15



IMPORTANT COUNTERWEIGHT INFORMATION

Ballast or Counterweight is not included with lift. (See Prices at Left)

We recommend using plate steel for counterweight or ballast of these approximate dimensions. 1 1/2" max. thickness x 5" wide x 19 1/2" long. Available from factory at price shown below or customer may supply his own weights.



Manual Lifting Products

Ideal for Machine Loading • Work-In-Process Handling Aids • Warehouse Lifting • Assembly Support

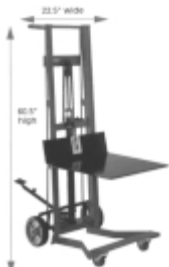

DPL-54-2222

- Hydraulic Peda-Lift
- 54" Lift Height
- 22" x 22" Platform
- Urethane Front Casters
- 750 lb. capacity
- \$(Call)



WL-54-F

- Hydraulic Peda-Lift
- 54" Lift Height
- Adjustable 18" Deep Forks
- 750 lb. capacity
- \$(Call)



WPL-54-2222

- Winch Peda-Lift
- 54" Lift Height
- 22" x 22" Platform
- 750 lb. capacity
- \$(Call)



ESPL-60-2424

- Hydraulic Stacker
- 60" Lift Height
- 24" x 24" Platform
- Phenolic Wheels
- 1,000 lb. capacity
- \$(Call)



RGD-4242

- Pallet Dolly Optional Push Handle
- Welded Aluminum
- Capacities to 12,000 lbs.
- 3,000 lb. Six Wheel - Tilt \$(Call)
- 6,000 lb. 8 Wheel - Tilt \$(Call)
- 9,000 lb. 10 Wheel - Tilt \$(Call)
- Optional Push Handle - add \$(Call) (#380054)

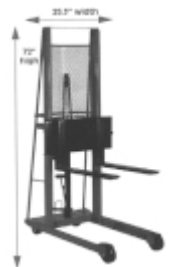

ESFL-56-25

- Hydraulic Stacker
- 76" Lift Height
- 30" Deep Adjustable Forks
- Phenolic Wheels
- 1,000 lb. capacity
- \$(Call)



LT-05-1818

- Hydraulic Table Lift
- 18" x 18" Table Top
- Lifts to 47" High
- Phenolic Wheels
- 500 lb. capacity
- \$(Call)



LT-60-2436

- Hydraulic Lift Table
- 24" x 36" Table Top
- Lifts to 59" High
- Phenolic Wheels
- 6,000 lb. capacity
- \$(Call)

Chain Hoists

Features:

- Available in 10 and 20 foot lifts
- Hardened load chain for long life
- Low headroom for easy installation in tight areas
- Lubrication free load brake for positive load control
- Swivel hooks with latches on all models



Part #	Capacity	Lift Height	Approx. Weight	Distance Hook to Hook	Chain Pull to Lift Rated Load	Hand Chain Overhaul for 1' Lift	Price Ea.
272163	1,000 lbs.	10'	19.5 lbs.	9.5"	50 lbs.	30'	\$(Call)
272164	2,000 lbs.	10'	24 lbs.	10.6"	70 lbs.	38'	\$(Call)
272165	3,000 lbs.	10'	35.5 lbs.	13.75"	80 lbs.	59'	\$(Call)
272166	4,000 lbs.	10'	33 lbs.	15"	70.6 lbs.	80'	\$(Call)
272167	6,000 lbs.	10'	52 lbs.	18.5"	82.5 lbs.	135'	\$(Call)
272168	10,000 lbs.	10'	81.5 lbs.	23.6"	90 lbs.	160'	\$(Call)
272169	1,000 lbs.	20'	31.5 lbs.	9.5"	50 lbs.	30'	\$(Call)
272170	2,000 lbs.	20'	35.5 lbs.	10.6"	70 lbs.	38'	\$(Call)
272171	3,000 lbs.	20'	52.5 lbs.	13.75"	80 lbs.	59'	\$(Call)
272172	4,000 lbs.	20'	50 lbs.	15"	70.6 lbs.	80'	\$(Call)
272173	6,000 lbs.	20'	76.5 lbs.	18.5"	82.5 lbs.	135'	\$(Call)
272174	10,000 lbs.	20'	117.5 lbs.	23.6"	90 lbs.	160'	\$(Call)

Tilt Master Fixed Forks Align with Outriggers (Not Usable with Closed Bottom Pallets or Containers)

PORTABLE TOTE BOX and BASKET TILTER Models TM20, TM40, TM60

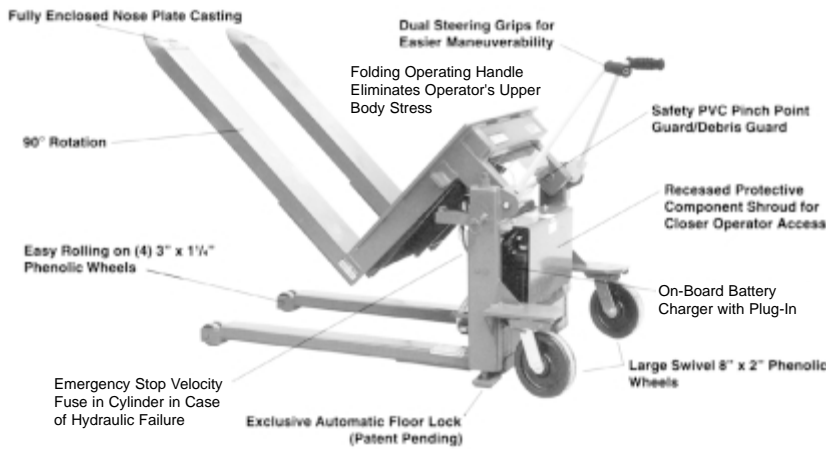

Specifications	TM20	TM40	TM60
Capacity (lbs.)	2,000	4,000	6,000
A. Load Center (rating Point) (in.)	20"	20"	20"
B. Lowered Height (in.)	3 1/2"	3 1/2"	3 1/2"
C. Lift (in.)	32"	32"	32"
D. Tilt Angle	90°	90°	90°
E. Fork Length (in.)	43"	43"	43"
F. Fork Width - O.D. (in.)	26"	26"	26"
Leg, Inner Dimension (in.)	14"	14"	14"
G. Fork Width (in.)	6"	6"	6"
H. Overall Length (in.)	72"	72"	72"
K. Width (in.) Including Wheels	45"	45"	45"
L. Height (in.)	28"	28"	28"
Weight (lbs.)	650	700	730
Load Wheels (in.)	3" x 1 1/2"	3" x 1 1/2"	3" x 1 1/2"
Casters (in.)	8"	8"	8"

HYDRAULICALLY TILTS BOXES AND BASKETS TO MAXIMUM EFFICIENCY WORK POSITIONS.

One operator lifts and positions filled tote boxes or baskets without the need of a fork truck or lift table. Functional as a basket tote box truck and a tilting table. Completed work may be moved to the next work station without waiting for a fork truck. Reduces back fatigue and injuries . . . increases productivity. Tilts up to 90°. Unit is available in manual, DC, A/C, and factory air.

New ergonomic assist: This unit includes a folding operating handle to get the worker close to the basket of products.

MODEL PRICING

- #TM20 (specify D/C, Battery, Air, A/C Plug in Power - **\$(Call)** - 2,000 lb. capacity
- #TM40 **\$(Call)** - 4,000 lb. capacity
- #TM60 **\$(Call)** - 6,000 lb. capacity

#BC

Built in D/C Battery Charger is included
Separate Bench Style DC Battery Remote Charger - Add **\$(Call)** As An Option

Automatic Floor Lock

For Enhanced Safety: The Automatic Floor Lock is one of the best features yet. When the operator tilts the unit to 15° it triggers the floor lock to position itself automatically to the floor. With this feature you never have to worry about the unit shifting during production.

Compact Accessible Design

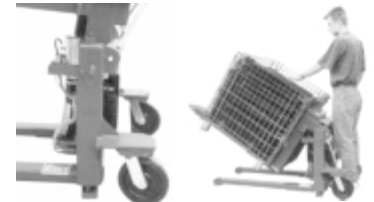

Tilt Master Straddle

Models TMS20, TMS40 - 2 Button Pendant Control

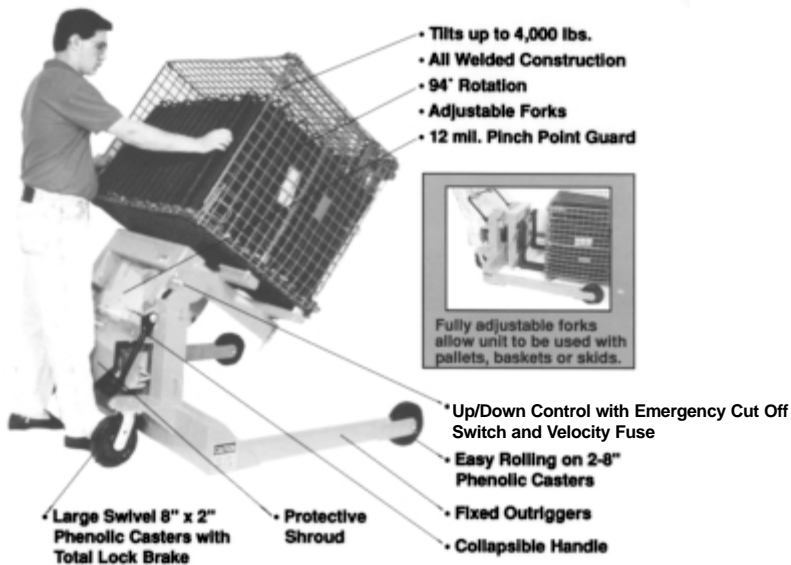

Features Adjustable Forks and Fixed Wide (50" I.D.) Straddle to Handle Hydraulic Tilting of up to 48" Wide Pallet Boxes and Open or Closed Baskets and Skids of all Types.

Specifications	TMS20	TMS40
Capacity (lbs.)	2,000	4,000
A. Load Center (Rating Point) (in.)	20"	20"
B. Lowered Height (in.)	3"	3"
C. Lift (in.)	35 1/2"	35 1/2"
D. Tilt Angle	94°	94°
E. Fork Length (in.)	36"	36"
F. Fork Width - O.D. (in.)	27"	27"
Leg, Inner Dimension (in.)	50"	50"
G. Fork Width (in.)	5"	5"
H. Overall Length (in.)	62"	62"
K. Width (in.)	56"	56"
L. Height (in.)	27 1/2"	27 1/2"
Weight (lbs.)	650	700
Load Wheels (in.)	8"	8"
Casters (in.)	8"	8"

MODEL PRICING

- #TMS20 (specify D/C, Battery, Air, or A/C Plug in Power - **\$(Call)**)
- #TMS40 **\$(Call)** (same choices as above)

#BC08 Built in D/C Battery Charger Remote is Standard
#BC Separate Bench Style DC Battery Remote Charger - Add **\$(Call)** as an option

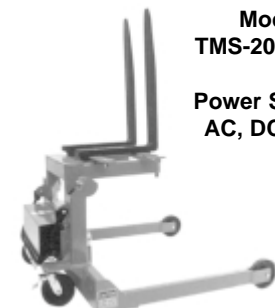

Models:
TMS-20, TMS-40

Power Supplies:
AC, DC, air/Oil

TT Dandy Lift Provides an Ergonomic Choice

- End Back Injuries ■ Simplify Work Positioning
- Avoid Expensive Compensation Claims n Reduce Cycle Time

- Handle work in process, components, parts, dies, and subassemblies with ease.
- Lift, position or transport virtually anything up to 1,760 pounds.
- End lifting injuries



Loading paper onto printing press



Positioning electronic assemblies



Transporting and lifting nursery plants



Lifting and moving office equipment.



Feeding and offloading parts at machine tool.



Positioning work in repair shop.



Transporting and lifting heavy computer forms



Portable work surface for electrical repair.



Loading shelves in stockroom



Positioning cabinets in construction.

ONE-YEAR WARRANTY: Dandy Lifts are warranted against defects in materials or workmanship for a period of one year from time of shipment. For full warranty details, see warranty statement included with each Dandy Lift.

Special sizes and custom designs are available for most items on adjoining pages. However the units shown below are not readily modified from the dimensions shown here. Call or FAX Ted Thorsen with a description of your process and requirements. We will respond promptly with an economical and appropriate quotation from the many available choices.

L-150 — 330 lbs. capacity



- Ideal for office and light industrial handling
- Attractively finished in blue enamel and chrome

- Parking lock
- Steerable caster-type wheels
- Carrying handle for portability
- Price: **\$(Call)**

Cap. lbs.	Bed Size (l x w)	Bed Ht.	Overall Size (l x w)
330	28" x 17 1/4"	8 5/8" - 29"	37 1/2 x 17 3/4"

A-500 — 1,100 lbs. capacity



- Lifts to over 3 feet.
- Handles over 1/2 - ton
- Parking lock
- Steerable caster-type wheels
- Price **\$(Call)**

Cap. lbs.	Bed Size (l x w)	Bed Ht.	Overall Size (l x w)
1,100	35 3/4" x 23 3/8"	11 7/8" - 36 5/8"	42 x 23 3/8"

A-350W — 770 lbs. capacity



- Over 4 feet of lifting height
- Parking lock
- Rapid rise
- Steerable casters
- Price **\$(Call)**

Cap. lbs.	Bed Size (l x w)	Bed Ht.	Overall Size (l x w)
770	35 3/4" x 23 3/8"	13 7/8" - 49 7/8"	42 x 23 3/8"

L-250 — 550 lbs. capacity



- Handles 1/4 ton-loads easily
- Elevates to almost 32 inches
- Parking lock
- Steerable cast-er-type wheels
- Price **\$(Call)**

Cap. lbs.	Bed Size (l x w)	Bed Ht.	Overall Size (l x w)
550	31 1/2" x 19 3/4"	9 5/8" - 32"	38 1/4 x 19 3/4"

A-800 — 1,760 lbs. capacity



- Over 40 inches lift height
- 20-1 mechanical advantage hydraulic system
- Parking lock
- Steerable cast-er-type wheels
- Price **\$(Call)**

Cap. lbs.	Bed Size (l x w)	Bed Ht.	Overall Size (l x w)
1,760	39 3/4" x 23 3/8"	13" - 40 1/4"	46 x 23 3/4"

M-500 Low Profile — 1,100 lbs. capacity (M500L)



- Only 3 1/8 inches in lowered position
- Ideal for handling low-clearance skids, wire baskets, containers, machinery, etc.
- Choice of 37" Fork Blades or Platform
- Elevates to 29 1/2 inches.
- Price **\$(Call)**

Cap. lbs.	Bed Size (l x w)	Bed Ht.	Overall Size (l x w)
1,100	37" x 19 3/4"	3 1/8" - 29 1/2"	55 1/2 x 19 3/4"

DLV150-DLV550 Spring Leveling Tables

Transporter/Feeder Automatically Raises and Lowers as Load Changes



Features:

- Height of load automatically adjusts to ideal height for loading and unloading.
- Minimizes bending and crouching.
- Simple structure is virtually maintenance free.
- Supports diverse loading needs.
- Caster lock for parking.
- A simple turn of the handy adjusting knob adjusts for load weight.

Specifications:

Model	Max. Cap.	Overall Dimens. Length	Handle Width	Platform Height	Platform Length	Platform Width
DLV-150	330 lbs.	32.6"	17.7"	36.0"	28.0"	17.7"
DLV-500	1100 lbs.	42.1"	23.6"	37.4"	35.8"	23.6"

Model	Low Height	Vertical Travel	Raised Height	Ship. Wt.	Price Ea.
DLV-150	10.8"	15.3"	26.2"	100 lbs.	[Call]
DLV-550	15.0"	16.5"	31.5"	210 lbs.	[Call]

Other sizes and designs are available, including battery powered and self-propelled units.

Please Call Ted Thorsen.

